

# ATH

ADVANCED THERMAL HYDRONICS



# KN SERIES

## Cast Iron Condensing Boilers

### Models KN-2 and KN-4

# Boiler Manual

## Installation and Operation Instructions

Also read and follow:

- KN Control Manual
- KN Vent/Air Manual



KN-2 only

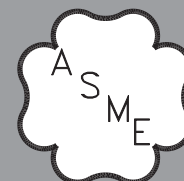

H

**WARNING** This manual is intended only for use by a qualified heating installer/technician. Read and follow this manual, all supplements and related instructional information provided with the boiler. Install, start and service the boiler only in the sequence and methods given in these instructions. Failure to do so can result in severe personal injury, death or substantial property damage.

**WARNING** **Do not use the boiler during construction.** Construction dust and particulate, particularly drywall dust, will cause contamination of the burner, resulting in possible severe personal injury, death or substantial property damage. The boiler can only be operated with a dust-free air supply. Follow the instruction manual procedures to duct air to the boiler air intake. If the boiler has been contaminated by operation with contaminated air, follow the instruction manual guidelines to clean, repair or replace the boiler if necessary.

**CAUTION** Affix these instructions near to the boiler/water heater. Instruct the building owner to retain the instructions for future use by a qualified service technician, and to follow all guidelines in the User's Information Manual.

# The KN condensing cast iron boiler

## Operation

### Overview

The **KN** is a cast iron boiler designed and constructed to allow full condensing operation. The illustration at left shows how the boiler is heated with a down-fired premix gas burner mounted above the heat exchanger. The **KN** blower pulls gas and air through a venturi assembly and pushes the mixture into the burner. The power of the blower forces the flue products through the heat exchanger and out the vent.

Boiler operation is controlled with the **KN** electronic control. The control modulates boiler firing rate based on system demand, allowing input as low as 20% of maximum (5:1 turndown). Combined with the indoor or outdoor reset option of the **KN** control, this allows maximum possible condensing mode operation, with thermal efficiency up to 99% at minimum input.

### Cast iron heat exchanger

The **KN** cast iron heat exchanger uses graphite port seals and ground joint fit-up between sections for maximum flexibility and resistance to thermal expansion. The heat exchanger provides maximum heat transfer with its counterflow design and flow-controlling baffle assembly.

### Premix burner

Premix means the air and gas are mixed before they enter the burner. The mixing of gas and air in the blower and piping ahead of the burner causes a uniform gas/air mix in the burner, providing reliable operation with low excess air. The result is exceptional combustion efficiency.

The burner consists of a high-temperature stainless mesh secured to a stainless steel distributor plate. The design causes uniform flame across the entire surface of the burner and the ability to operate at very low firing rates. The flame is ignited with direct-spark electrodes and an electronic ignition control. Flame is proven using a flame rod (flame rectification sensing).

Because of its low excess air operation and controlled combustion, the burner also provides low NO<sub>x</sub> emissions and quiet operation.

### Gas valve, blower and venturi

Most gas valves regulate at a positive pressure downstream of the valve (typically 3½ inches water column). But the **KN** gas valve regulates to ZERO pressure downstream. This is called a “zero governor” valve. The advantage is that gas will only flow if something lowers the pressure downstream of the valve below zero. That is just what happens when the blower pulls air through the venturi. As the air speeds up to pass through the narrow throat of the venturi, a vacuum forms in the throat. The more air that flows through the throat, the greater the vacuum.

The gas valve raises the negative pressure in the venturi to zero by letting gas flow. The lower the pressure in the venturi throat, the more gas will that will flow. So gas flow automatically adapts to air flow, ensuring consistent gas/air mix throughout the boiler’s modulating range. Thus, the **KN** HeatNet® electronic control regulates the blower speed to control boiler firing rate.

### KN HeatNet® control

The **KN** HeatNet® electronic control consists of a microprocessor-based module and a keypad/display unit for user interface. The control regulates boiler water temperature by adjusting boiler firing rate (by varying the blower speed). The control considers how fast the temperature changes and how the temperature varies over time to establish the best firing rate to meet demand. Options include an outdoor sensor for outdoor reset operation and an indoor reset option. (Indoor reset monitors up to 8 zone thermostats and determines a maximum firing rate needed to meet the demand. This keeps the boiler at the highest possible efficiency.) In addition, the control can be set for multiple boiler operation, either stand-alone or utilizing on-board HeatNet® technology. The control also automatically cycles the factory-installed postpurge circulator to equalize residual heat in the boiler after firing.

### The KN condensing cast iron boiler

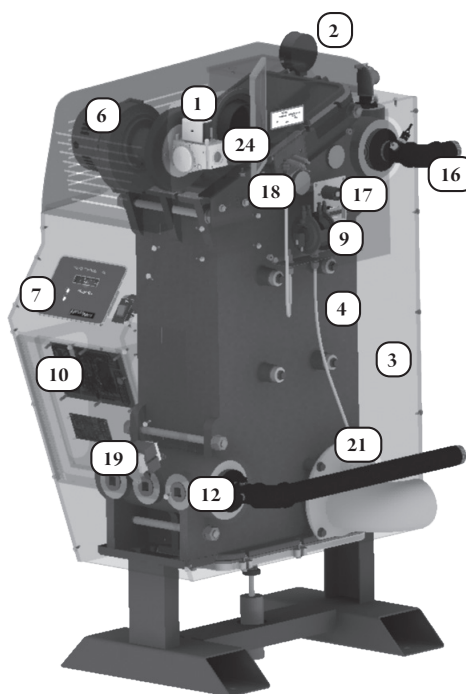
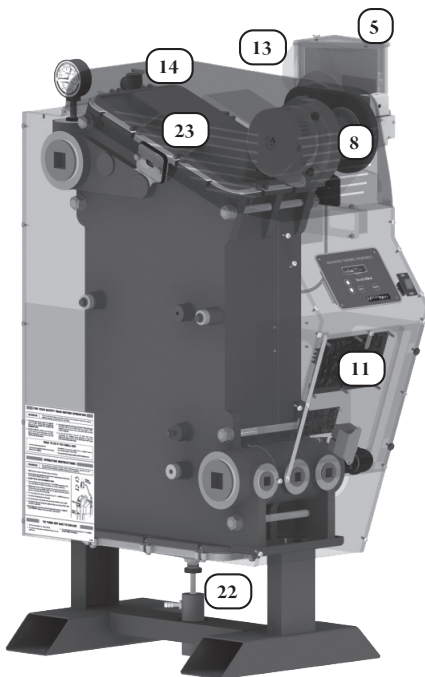
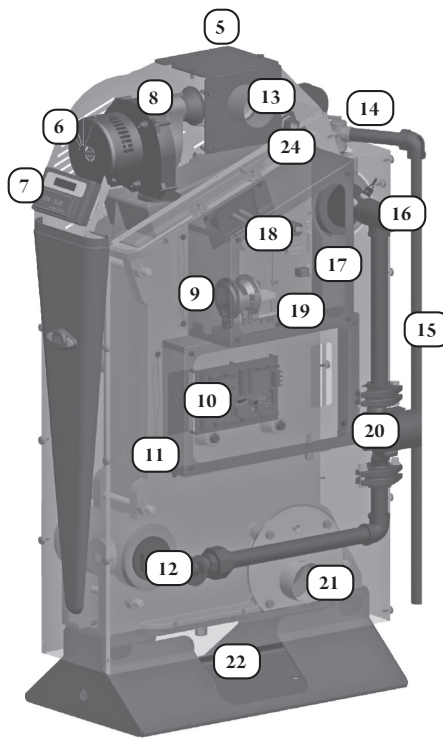
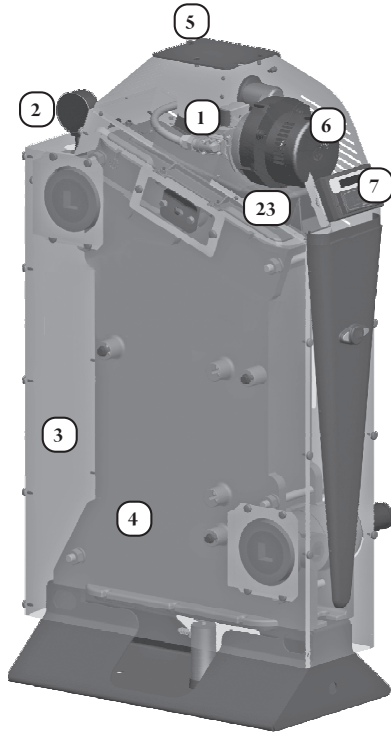

#### Components

1. Gas valve
2. Pressure/temperature gauge
3. Jacket
4. Cast iron section assembly
5. Inlet air filter access panel
6. Blower
7. KN HeatNet® control with keypad and display
8. Venturi assembly
9. Pressure switches (blocked flue and blocked air inlet)
10. Control connection board
11. Electrical box (power and control entrances)
12. Water return connection
13. Air inlet sleeve
14. Relief valve
15. Relief valve piping (by installer)
16. Water supply connection
17. Fenwal ignition module
18. Ignition electrodes/flame rod assembly
19. Control transformer (120/24 VAC)
20. Postpurge circulator, factory-installed and piped
21. Vent connection sleeve (with flue gas sampling port)
22. Condensate tubing connection
23. Upper section cover and premix burner
24. Gas connection, ½" NPT

**KN**  
components

# Contents

- 1 Read before beginning the installation . . . . . 5
- 2 Boiler ratings and specifications. . . . . 6
- 3 Installation site preparation . . . . . 7
- 4 Prepare the boiler . . . . . 10
- 5 Water piping . . . . . 11
- 6 Gas piping. . . . . 18
- 7 Wiring a single boiler. . . . . 20
- 8 Control setup. . . . . 25
- 9 Vent piping (and air piping when used) . . . 28
- 10 Condensate drain line . . . . . 29
- 11 Fill and test the system. . . . . 30
- 12 Starting the boiler. . . . . 32
- 13 Annual start-up . . . . . 41
- 14 Maintenance . . . . . 42
- 15 Replacement parts . . . . . 46
- 16 Appendix A — suggested wiring . . . . . 48

## Hazard icons

You will find the following icons throughout this manual. (English/French)



The **WARNING** icon indicates a hazard that can cause *severe personal injury, death or substantial property damage*.



The **CAUTION** icon indicates a hazard that will or can cause *minor personal or property damage*.



The **NOTICE** icon calls out special instructions that are important, but are not related to hazards.

## Other manuals



You must read and follow this manual, the **KN Vent/Air manual**, the **KN Control manual** and all additional materials supplied with the boiler. Failure to do so can result in severe personal injury, death or substantial property damage.

## Start-up/service history

Before leaving the installation site after start or service, fill out the Start-up/service history information on the back page.

### Customer service and technical support

Please direct all questions to your distributor or contact the Advanced Thermal Hydronics Customer Service Department at:  
 260 North Elm Street Westfield, MA 01085  
 Phone (833) 265-5371

Always include the model and serial numbers from the rating plate of the boiler in question.

Claims for damage or missing components must be filed immediately against the transportation company by the consignee.



# Read before beginning the installation

## Codes and standards

### Boiler compliances

The **KN** has been design certified by CSA for use with natural and propane gas under the latest revision of ANSI-Z21.13/CSA 4.9, Gas-Fired Low Pressure Steam and Hot Water Boilers and CAN1-3.1, Industrial and Commercial Gas Fired Packaged Boilers. Each unit has been constructed and hydrostatically tested for a maximum working pressure of 100 psi (700 kPa), in accordance with Section IV of the A.S.M.E. Boiler and Pressure Vessel Code.

### Code compliances

All aspects of the boiler installation must conform to the requirements of the authority having jurisdiction, or, in the absence of such requirements, to the National Fuel Gas Code, ANSI Z223.1/NFPA 54-latest revision. Where required by the authority having jurisdiction, the installation must conform to the Standard for Controls and Safety Devices for Automatically Fired Boilers, ANSI/ASME CSD-1.

In Canada, the installation must be in accordance with the requirements of CSA B149.1 or .2, Installation Code for Gas Burning Appliances and Equipment.

### Commonwealth of Massachusetts

If installing a **KN** boiler in the Commonwealth of Massachusetts, you **MUST FOLLOW** the additional instructions contained in Advanced Thermal Hydronics' instruction sheet, MA CODE. If you don't have a copy, call your dealer or Advanced Thermal Hydronics.

When installed in the Commonwealth of Massachusetts, ensure the following:

- The boiler must be installed by a licensed plumber or gas fitter.
- When antifreeze is used in the system, install an approved pressure back-flow preventer.
- Per DOE mandate, the **KN-2** operator control incorporates an automatic means (outdoor/indoor air reset) of adjusting the boiler water temperature for hot water heating. The boiler must not operate without the automatic means enabled.

#### IMPORTANT

In accordance with Section 325 (f) (3) of the Energy Policy and Conservation Act, this boiler is equipped with a feature that saves energy by reducing the boiler water temperature as the heating load decreases. This feature is equipped with an override which is provided primarily to permit the use of an external energy management system that serves the same function.

THIS OVERRIDE MUST NOT BE USED UNLESS AT LEAST ONE OF THE FOLLOWING CONDITIONS IS TRUE:

- An external energy management system is installed that reduces the boiler water temperature as the heating load decreases.
- This boiler is not used for any space heating.
- This boiler is part of a modular or multiple boiler system having a total input of 300,000 BTU/hr or greater.
- This boiler is equipped with a tankless coil.

## Before placing the boiler . . .

### Verify boiler rating and gas supply

- Before installing the **KN** boiler, check the rating plate to ensure that the unit has been sized properly for the job.
- Ensure that the boiler is set up for the type of gas available at the installation site.

### Verify location is suitable

- Ensure the availability of an adequate electrical supply, uncontaminated air for combustion, and that vent (and air) piping can be correctly installed.
- Ensure the boiler can be connected to system water piping and gas supply.
- The boiler must not be exposed to dripping or spraying water or to rain.
- If replacing an existing boiler, find out what caused the boiler to fail before installing a new boiler. Correct the problems that led to failure, or the failure may happen to the new boiler.

#### **WARNING**

Do not install or operate the boiler, or leave an installation, without complying with all of the following, and with all information supplied in the boiler manuals.

### Should overheating occur

- Do not shut off power to the circulators if the boiler should overheat or the gas supply fail to shut off. Instead, shut off gas supply to the boiler with a manual valve in the gas supply line.

### When servicing or operating the boiler

- Disconnect electrical power when servicing the boiler to avoid potential for electrical shock.
- Allow the boiler, components and water to cool before attempting to remove or handle boiler parts.
- Do not add cold water to the boiler if it is hot. Allow the boiler to cool completely before introducing cold water.
- Do not operate the boiler if any part has been under water.
- Follow the guidelines in the Maintenance section for dealing with fiberglass and ceramic fiber materials.

### You must have the following equipment

- Electric multimeter
- Surface temperature gauge
- Pressure differential gauge or included DP manometer
- (3) Gas pressure meters: Two @ 0 – 14 inches WC; One @ 0 – 5 psi
- Combustion analyzer — You must use a combustion analyzer and follow all instructions in this manual to correctly start-up the boiler. As prescribed in this manual, the O<sub>2</sub> levels must be between 5% and 7%. Throughout all firing rate conditions, the burner surface must never show red areas. Follow manual procedures to correct this condition.
- Ammeter
- Metric Allen wrenches

### Boiler water

- You must thoroughly flush the system, with the boiler isolated from the system, to remove sediment. Existing systems, in particular, often contain large amounts of iron sediment. Excess suspended solids in the water can lead to premature boiler failure.
- High efficiency equipment requires suitable water for reliable operation. Follow the ASME recommendation for water treatment on hydronic applications that have dissolved solids greater than 200 parts per million. Fill water must be softened if the solids concentration is higher than this. See additional guidelines in this manual.
- Do not allow the boiler to operate with frequent introduction of make-up water. Correct all problems causing leaks, relief valve weeping, or other factors that could cause fresh water to be added.
- Do not use automotive anti-freeze in the boiler waterways. If the use of antifreeze is necessary, an anti-freeze specifically formulated for hydronic heating systems must be used or damage to the boiler may occur, voiding the warranty.
- On applications that use antifreeze or other low conductivity fluid in the water, provide for increased water flow or ensure proper temperature rise.

### Train the user

- Before leaving, review the User's Information Manual with the boiler user/homeowner, including the required maintenance to be performed by the user, the need for annual start-up/maintenance by a qualified technician, the avoidance of combustion air blockage or contamination, and never bringing or storing flammable products into the boiler area.

2

# Boiler ratings and specifications



**KN-2 only**

Boiler model	Units	KN-2	KN-4	Notes
AFUE (DOE seasonal efficiency)	%	90	N/A	1
CSA Input (Max)	Btuh Kw	199,999 59	399,999 116.8	2
CSA Input (Min)	Btuh Kw	40,000 11.7	80,000 23.4	2
Maximum allowable working pressure	PSIG kPa	100 689		
Water supply and return connections	Inches, NPT	1¼		
Boiler water volume	Gallons Liters	3.9 14.8	5.9 22.3	
Shipping weight	Pounds Kg	540 245	780 354	
Operating weight	Pounds Kg	563 256	753 341	
Fuels		Natural gas or propane		3
Gas connection size	Inches, NPT	½	¾	
Gas supply pressure, minimum	Inches WC mm WC	2 50.8		
Gas supply pressure, maximum	Inches WC mm WC	14 356		
Vent connection size	Inches mm	3 76.2	4 101.6	
Vent options		Direct Vent or Category IV and II		
Combustion air options		Air from boiler room or ducted to boiler from outside		
Combustion air adapter size	Inches mm	3 76.2	4 101.6	
<b>Electrical requirements</b>				
Voltage		120 vac/60 hz/1-phase		
Current draw (120-volt power line)	Amperes	2.5	5	
Thermostat anticipator setting	Amperes	0		5
Operating control		HeatNet control		4
Control operation options		Stand-alone HeatNet BMS (boiler management system)		4
Control methods		Heat demand (HeatNet or stand-alone) On/Off BMS (4-20 ma input) Staging RS485 digital communication		4

**Notes**

- 1 DOE Heating capacity is based on standard tests specified by the United States Department of Energy.
- 2 All capacity ratings above are based on sea level. Input adjustments allow setting the high fire input and may compensate for moderate altitudes. For higher altitudes the maximum boiler input will be derated slightly.
- 3 The gas valve is capable of operating with natural gas or LP. See instructions in this manual to adjust for the specific fuel used.
- 4 For additional information, refer to the **KN** Control manual.
- 5 Thermostat anticipator setting is for a single thermostat connected to a single **KN** boiler. Also jumper from the Heat Demand terminals to the IAR1 terminals on the connection board. See the **KN** Control manual for details.

# 3

## Installation site preparation

### Boiler location requirements

**⚠ WARNING** Do not install the boiler unless the location meets all of the requirements in this box. Failure to comply could result in severe personal injury, death or substantial property damage.

#### Indoor installation only

- Do not install the boiler outside or in an area that would expose the boiler or its gas or electrical components to rain or dripping or spraying water.
- Do not install the boiler in a location that would subject the boiler to freezing. Where freeze protection is needed, follow the guidelines in this manual.

#### Flooring

- The boiler can be installed on combustible flooring, but must not be installed on carpeting.
- The floor must be structurally sound and capable of supporting the weight of the boiler.
- The boiler must be leveled front to back and side to side. Use metal shims if necessary.

#### Accessibility

- Jacket parts will have to be removed for some service procedures. Ensure that the location provides a reasonable means for service and operation of the boiler.

#### System piping, fuel and electrical supply

- The boiler must be located such that piping for water, gas, vent and air can reasonably be connected.
- There must be a reasonable means of providing electrical supply to the boiler.

#### Adjacent construction

- Locate the boiler in an area that will prevent water damage to adjacent construction should a leak occur or during routine maintenance.

#### Combustion air

- Do not place the boiler in a location that would restrict the flow of combustion air into the air intake or subject the boiler to a negative air pressure in the space when using air from the boiler room.
- Provide required combustion air openings to the boiler room and the building (when required) when using air from the boiler room for combustion (see page 8). If air is piped to the boiler air intake connection, combustion air openings are not required unless other appliances share the same room.

- Buildings will require the installation of a fresh air duct or other means of providing make-up air if the intake air option isn't used. Any building utilizing other gas burning appliances, a fireplace, wood stove or any type of exhaust fan must be checked for adequate combustion air when all of these devices are in operation at one time. Sizing of an outside air duct must be done to meet the requirements of all such devices.
- The boiler must be supplied with combustion air in accordance with Section 9.3, "Air for Combustion and Ventilation," of the latest revision of the National Fuel Gas Code, ANSI Z223.1/NFPA 54 and all applicable local building codes. Canadian installations must comply with CSA B149.1 or .2 Installation Code for Gas Burning Appliances and Equipment, or applicable provisions of the local building codes.

#### Negative room pressure

- Never operate the boiler in an environment subjected to a negative pressure unless it is Direct Vented. Failure to comply with this warning can result in excessive levels of carbon monoxide.

#### Combustion air contamination

- Combustion air contaminated with fluorocarbons or other halogenated compounds such as cleaning solvents and refrigerants will result in the formation of acids in the combustion chamber. These acids will cause premature failure of the boiler.
- **Construction dust:** If the boiler is operated while the building is under construction it must be protected from wood, concrete, sheet rock and other types of dust. Failure to properly protect the boiler from construction dust will damage the boiler.
- If the boiler has been operated with contaminated air, it must be thoroughly inspected. Where possible, boiler components must be cleaned, following instructions provided in this manual and/or supplementary instructions from Advanced Thermal Hydronics. Where cleaning is not possible, the boiler may have to be replaced.
- Never store combustible materials, gasoline or any product containing flammable vapors or liquids in the vicinity of the boiler.

#### Clearances

- All installation must provide the minimum clearances to combustible materials given on page 8.
- The installation should provide the minimum service clearances given on page 8 when possible. If these clearances cannot be met, then:
  - Ensure that boiler components can be accessed for operation/start-up/maintenance as required in the **KN** manuals.

### 3

## Installation site preparation *(continued)*

### Clearance requirements

#### Clearances to combustible surfaces

**⚠ WARNING** All installations must provide the minimum clearances to combustible materials and surfaces given in Table 1. Failure to comply could result in a fire hazard, causing severe personal injury, death or substantial property damage.

**Table 1** Minimum clearances to combustible materials/surfaces for ALL installations (Figure 1)

From:	Inches	Millimeters
Top	6	153
Back	6	153
Left side	6	153
Right side	6	153
Front	6	153
Rear	6	153
Vent piping	2	51
System water piping	1	25.4

**⚠ WARNING** If the boiler is located in a closed room, the room must be provided with ventilation openings even if air is ducted to the boiler. See Figure 1. Size the openings with a free area no less than 1 square inch per BTUH input of all KN boilers in the room.

EXCEPTION: Ventilation openings are not required if the boiler room provides at least the minimum SERVICE/OPERATION clearances given in Table 2. Failure to provide adequate ventilation could result in overheating of the boiler components or the room, potentially causing severe personal injury, death or substantial property damage.

#### Clearances for service and operation

**⚠ WARNING** The installation must provide reasonable access and clearance for service and operation of the boiler. Table 2 gives recommended minimum clearances for service and operation. The boiler may be installed in a space that does not provide these recommended clearances provided it is accessible for the service and operation procedures required in the KN manuals.

**Flame observation port** — The flame observation port on the LEFT side of the boiler must be accessible to view the combustion chamber during boiler start-up. Make sure that the installation allows serviceman access to the left side for this purpose.

**Table 2** Recommended minimum clearances for service/operation (Figure 2)

From:	Inches	Millimeters
Top	24	610
Back	24	610
Left side	24	610
Right side	24	610
Front	36	914
Rear	18	457

**Figure 1** Clearance to combustibles references

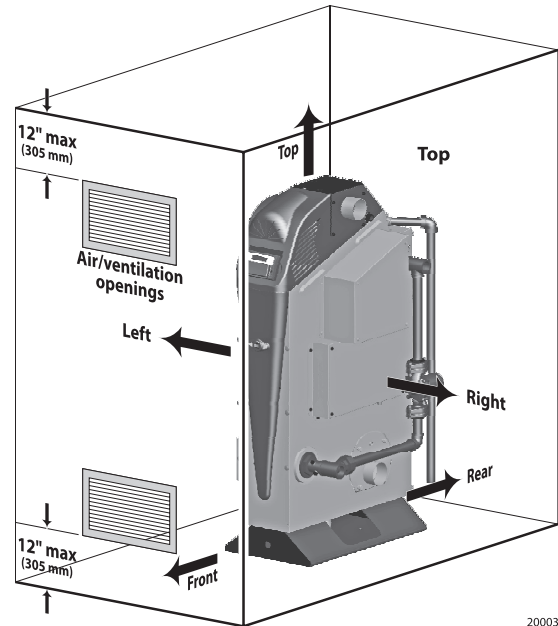

20003

**⚠ WARNING** This product burns gas to produce heat. The appliance must be properly installed, operated, and maintained to avoid exposure to appreciable levels of carbon monoxide and the installer is required to confirm that at least one carbon monoxide alarm is installed in the living space before the appliance is put into operation. It is important for the carbon monoxide alarms to be installed, maintained, and replaced following the alarm manufacturer's instructions and applicable local codes.

**Figure 2** Service/operation clearance references

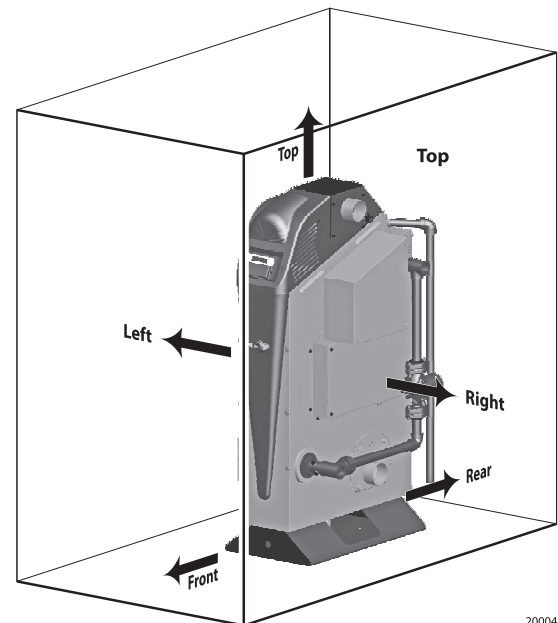

20004



3

# Installation site preparation *(continued)*

## Combustion air requirements

### Air ducted to boiler air intake

If air is ducted from outside to the boiler air intake, follow instructions in the **KN Vent/Air** manual to size and install the air piping.

If the boiler is located in a small room (clearances less than the recommended **SERVICE/OPERATION** clearances given in Figure 2):

- No other appliances in the room — Provide two ventilation openings through one of the enclosure walls. Each opening must be sized for a free area of at least 1 square inch per 1,000 BTUH input of the **KN** boilers in the room. One opening must be within 12 inches of the ceiling, the other within 12 inches of the floor.
- Other appliances in the same room — The room must have combustion air openings sized for the other appliances. Increase the free area of the air openings by one square inch per 1,000 BTUH of the **KN** boilers located in the room.

### Air from boiler room

When the boiler draws combustion air from the boiler room:

- If the room volume is at least 50 cubic feet per BTUH of the combined input of all appliances in the room, no special openings are needed **UNLESS** the building is of **tight construction**, provide openings to the **building** in accordance with all applicable codes.
- If the boiler is in a space smaller than 50 cubic feet volume per BTUH input, provide air openings using one of the methods in Figure 3.

### Definitions

**Free area** — Louvers or grilles reduce the area of an opening. Free area is the area remaining with the louver or grille in place. If the free area of a louver is unknown, use the following:

- Metal louver — Multiply required free area of the opening times 1.7 to determine actual area of the required opening.
- Wood louver — Multiply required free area of the opening times 5 to determine actual area of the required opening.

**Tight construction** — When a building is extensively sealed to prevent air infiltration, it cannot provide enough air for combustion unless openings are provided to the outside. The National Fuel Gas Code defines such buildings as having all of the following:

- Walls and ceilings exposed to the outside atmosphere have a continuous water vapor retarder with a rating of 1 perm or less with openings gasketed.
- Weather-stripping has been added on openable windows and doors.
- Caulking or sealants are applied to areas such as joints around windows and door frames, between sole plates and floors, between wall-ceiling joints, between wall panels, at penetrations for plumbing, electrical, and gas lines, and in other openings.

### Conversion factors

- In<sup>2</sup>/1,000 BTUH to cm<sup>2</sup>/kw** — Multiply **In<sup>2</sup>/1,000 BTUH** times **22**
- In<sup>2</sup>/2,000 BTUH to cm<sup>2</sup>/kw** — Multiply **In<sup>2</sup>/2,000 BTUH** times **11**
- In<sup>2</sup>/3,000 BTUH to cm<sup>2</sup>/kw** — Multiply **In<sup>2</sup>/3,000 BTUH** times **7.4**
- In<sup>2</sup>/4,000 BTUH to cm<sup>2</sup>/kw** — Multiply **In<sup>2</sup>/4,000 BTUH** times **5.5**

**Figure 3** Air opening options for combustion air drawn from boiler room

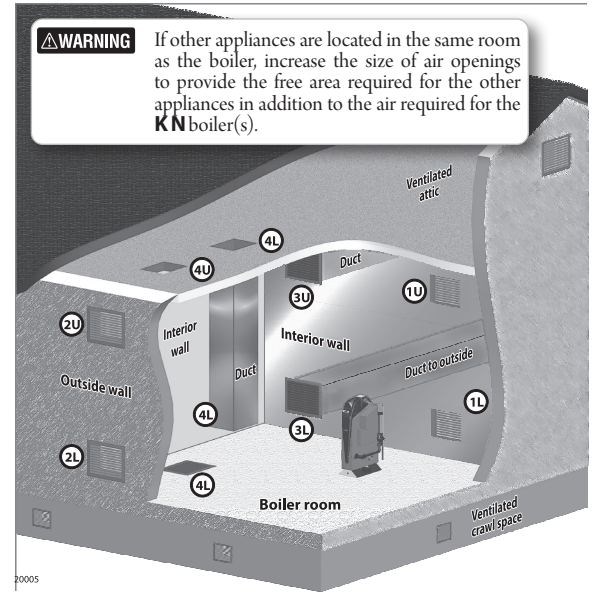

Upper openings (**U**) must be within 12 inches of the ceiling. Lower openings (**L**) must be within 12 inches of the floor.

#### Option 1 — air openings through interior wall

When air is supplied to the boiler room through openings in an interior wall (air supply from inside the building), size each opening to provide minimum free area of:

**1 in<sup>2</sup> per 1,000 BTUH** of all **KN** boilers in the room.

#### Option 2 — air openings through outside wall

When air is supplied to the boiler room through openings in an outside wall (air supply from outside the building), size each opening to provide minimum free area of:

**1 in<sup>2</sup> per 4,000 BTUH** of all **KN** boilers in the room.

#### Option 3 — horizontal ducts to outside wall

When air is supplied to the boiler room through horizontal ducts to an outside wall (air supply from outside the building), size each opening to provide minimum free area of:

**1 in<sup>2</sup> per 3,000 BTUH** of all **KN** boilers in the room.

#### Option 4 — openings to attic/crawl space

Air openings can be connected to a ventilated attic or crawl space. The upper opening must be to the attic. The lower opening can be a vertical duct from the attic or an opening in the floor from the crawl space. Size each opening to provide minimum free area of:

**1 in<sup>2</sup> per 3,000 BTUH** of all **KN** boilers in the room.

#### Option 5 — single opening (not shown)

A single opening directly connected to the outdoors through a wall or a vertical or horizontal duct can be used if the installation provides the clearances of Figure 2, and the top of the opening is within 12 inches of the ceiling. Size the opening to provide minimum free area of:

**1 in<sup>2</sup> per 3,000 BTUH** of all **KN** boilers in the room.



### 4

## Prepare the boiler

### Remove the boiler from the crate

**CAUTION** **Cold weather handling** — The boiler jacket includes plastic parts. If the boiler has been in a cold environment (below 0 °F), allow the boiler to warm to room temperature before handling.

**CAUTION** Do not drop the boiler or allow the jacket to bump against the floor or wall when handling.

1. Remove the crate from the skid. But leave the boiler on the skid to move the boiler near its location.
2. Inspect the boiler thoroughly for any possible damage that may have occurred in shipping or handling.
3. Slide the boiler off of the skid into position.
4. Use a spirit level to check whether the boiler sides and front are vertically plumb. If not, slide metal shims under the base until the boiler is level.

### Install the relief valve

#### Check relief valve pressure setting

Inspect the boiler relief valve before installing to ensure it is set at the pressure required for the system. You should also verify that all water system components are rated for at least the pressure setting of the relief valve to avoid component damage due to excess pressure.

**WARNING** The boiler maximum allowable working pressure is 100 psig (689 kPa). The relief valve must never have a setting greater than 100 psig. Using a higher pressure relief valve could result in an explosion, causing possible severe personal injury, death or substantial property damage.

#### Connecting the relief valve

Connect 3/4 inch NPT black iron pipe and fitting so the relief valve as shown in Figure 4. Follow all instructions provided in the relief valve manufacturer's instructions and labeling.

**WARNING** Never install any type of valve between the boiler and the relief valve, or in the relief discharge piping. An explosion could occur, causing severe personal injury, death or substantial property damage. General piping requirements.

### Boiler piping — general

**WARNING** Improper piping of the boiler will void the manufacturer's warranty, and can cause boiler failure, resulting in possible severe personal injury, death or substantial property damage.

**NOTICE** Install a shut-off valve in the boiler supply and return connections to allow isolation of the boiler for servicing when necessary.

### Piping guidelines:

- All installations must be installed by a qualified technician in accordance with the latest revision of the ANSI/ASME Boiler and Pressure Vessel Code, Section IV.
- Where required, the installation must comply with ANSI/ASME CSD-1, Standard for Controls and Safety Devices for Automatically Fired Boilers.
- All applicable local codes and ordinances must also be followed.
- A minimum clearance of 1 inch (25 mm) must be maintained between heating system pipes and all combustible construction.
- All heating system piping must be supported by suitable hangers — not by the boiler.
- The thermal expansion of the system must be considered when supporting the system.
- A minimum system pressure of 12 psig (84 kPa) must be maintained.

**Figure 4** Relief valve piping

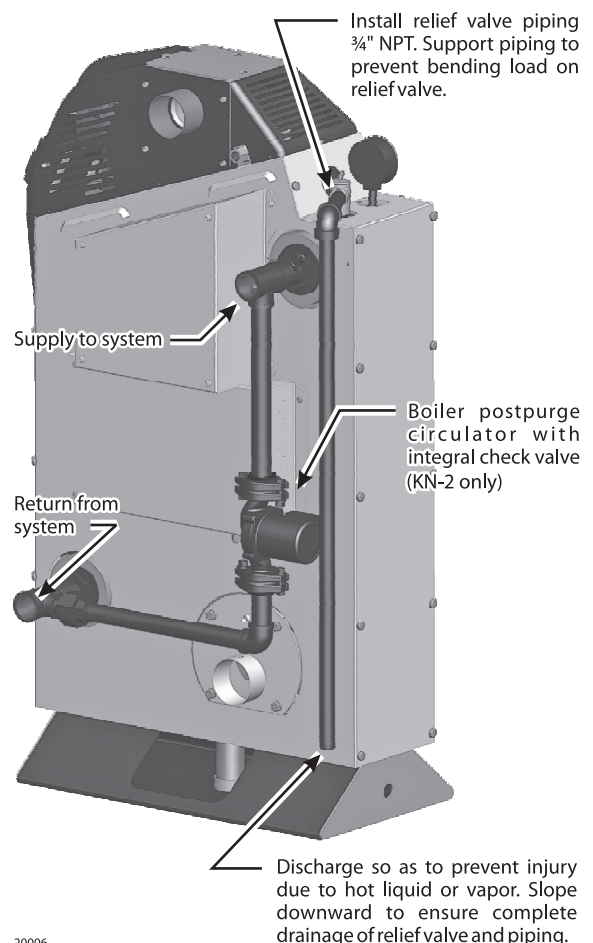

20006

## Water piping

### Boiler piping connections

The boiler supply and return connections are shown in Figure 4. Both connections are 1-1/4 inch NPT.

Size piping for the flow required. Piping connections to the **KN** boiler should generally be 1-1/4 inch NPT.

### System design

#### Design options

The **KN-2** boiler works well in a single or multiple-boiler application for any type of system. The following pages include suggested piping diagrams for the following system options:

- Single boiler, zoning with zone valves (page 13).
- Single boiler, zoning with circulators (page 14).
- Multiple boilers, primary/secondary piping (page 15).
- Multiple boilers, parallel piping, reverse-return (page 16).
- Guidelines for chilled water systems (page 17).

All of the piping diagrams show the suggested piping for optional indirect-fired DHW tanks. Follow the DHW tank manufacturer's instructions for installation and piping. Make sure to size the DHW circulator and piping to provide the flow needed for the required recovery capacity.

#### Pipe sizing

Generally install 1¼-inch piping in the boiler circuit. Size system and other circuit piping based on a 20°F temperature drop through the zones. For water-source heat pump systems, the primary circuit flow rate will usually be based on a 5°F temperature drop. Such high flow systems must be piped with the boiler on a separate loop.

#### Piping guidelines

**WARNING** **Support the piping** — All piping and components must be supported such that no loads or stresses are applied to the boiler. Allow for thermal expansion in the piping design and passageways.

**NOTICE**

The piping diagrams in this manual omit piping components such as unions. Always install unions where needed to simplify piping and improve serviceability.

### Circulator requirements

#### Boiler postpurge circulator

**NOTICE**

The **postpurge circulator** supplied with the **KN-2** (Figure 4), factory piped between the boiler supply and return connections, is **NOT** intended for use in the system. It must remain connected as supplied. The postpurge circulator is only used by the **KN-2** for postpurge flow to remove residual heat in the combustion zone. The postpurge circulator includes an integral check valve to prevent by-pass flow during operation.

**CAUTION**

The **KN** boiler requires a continuous minimum water flow for proper operation. The circulator for the boiler must be sized to overcome the head loss of the boiler and the heating system in order to achieve the required temperature rise. If the system contains hydronic antifreeze this must be considered when sizing the pump. The temperature rise across the boiler must never exceed 100°F (55.6°C).

#### Boiler flow and pressure drop

Maintain **KN-2** flow rate between 3.6 GPM @ 0.07 ft-hd to 18 GPM @ 1.87 ft-hd (13.6 to 68.1 LPM).

Maintain **KN-4** flow rate between 7.2 GPM @ 0.07 ft-hd to 36 GPM @ 1.9 ft-hd (27.3 to 136.3 LPM).

#### Boiler and system circulators

See the following pages for suggested piping for **KN** boilers. All circulators are supplied by the installer, except the factory-installed postpurge circulator on the **KN-2**.

**Boiler circulator** — the circulator that flows water through the boiler **KN-2** only.

**System circulator** — the circulator that flows water through the system, but not through the boiler.

**Boiler/system circulator** — a circulator that flows water through the boiler and the system.

#### Circulator activation

See section 7 of this manual and the **KN** Control manual for instructions on wiring boiler and system circulators.

The **KN** HeatNet Control provides an isolated contact to operate the **boiler circulator** (or boiler/system circulator).

The **system circulator** must be activated by a relay supplied by the installer. This relay is usually activated by the system control or thermostat.

### Additional controls

Local codes or job specifications may require the use of additional controls, such as low water cut-offs, flow switches, and high limit controls. Refer to the **KN** Control manual for electrical connections for auxiliary controls.

Follow the guidelines below to install typical controls in the piping.

#### Low water cut-off

When the boiler is installed above terminal units, or when required by applicable codes, install a low water cut-off in the piping above the boiler. See suggested piping in the diagrams in this section.

Use a probe-type control when possible.

#### Flow switch

When a flow switch is required, install the switch in a section of the piping that will ensure enough flow to operate the switch.

#### Additional high limit controls

For ASME CSD-1 or Canadian applications, or when required by applicable codes, install an additional high limit control in the supply piping above the boiler.

Make sure the limit control is set at least 20 °F above the highest operating temperature of the **KN** boiler.

### 5

## Water piping (continued)

### Expansion tank and air separation

The system must include an expansion tank to control thermal expansion. Install the tank as close as possible to the boiler, and locate on the suction side of the system circulator. Make sure the tank is sized large enough to handle the system volume.

**Figure 5** Expansion tank comparison

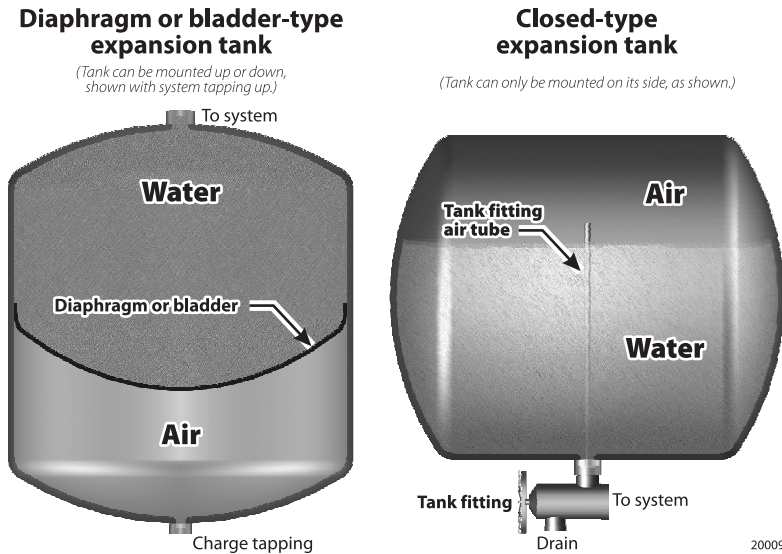

### Diaphragm/bladder type expansion tank

Diaphragm or bladder-type expansion tanks have a membrane that separates the water from the air in the tank. See Figure 5, left side. See Figure 6 for suggested piping.

#### Guidelines for diaphragm/bladder-type expansion tanks

- Always remove the tank from the system before charging. This ensures the air pressure will be accurate. Make sure the charge pressure equals the required system cold-fill pressure (usually 12 psig).
- Install an automatic air vent on top of the air separator to remove air from the system.

### Closed-type expansion tank

Closed-type tanks are those that have air above the water, in direct contact with the water. See Figure 5, right side. See Figure 7 for suggested piping.

#### Guidelines for closed-type expansion tanks

- **NEVER** use automatic air vents in systems with closed-type tanks. The air must be kept in the system, and returned to the tank, in order to keep the tank operating correctly. Automatic air vents will bleed air out of the system, resulting in water-logging of the tank, causing the boiler relief valve to weep.
- Air separation is done by connecting from an in-line air separator to the bottom of the expansion tank (Figure 7). The tank must be mounted above the air separator.
- Install a tank fitting in the bottom of the tank. It allows captured air to flow into the upper portion of the tank, facilitates filling, and reduces recirculation in the expansion tank piping.

### Cold water fill

Follow all applicable codes when connecting the cold water fill to the piping. Use a backflow preventer where required. See suggested piping on this and the following pages. Also consider installing a water meter on the cold water make-up line. The water meter will show if excessive make-up water is entering the system.

**Figure 6** Diaphragm or bladder-type expansion tank suggested piping

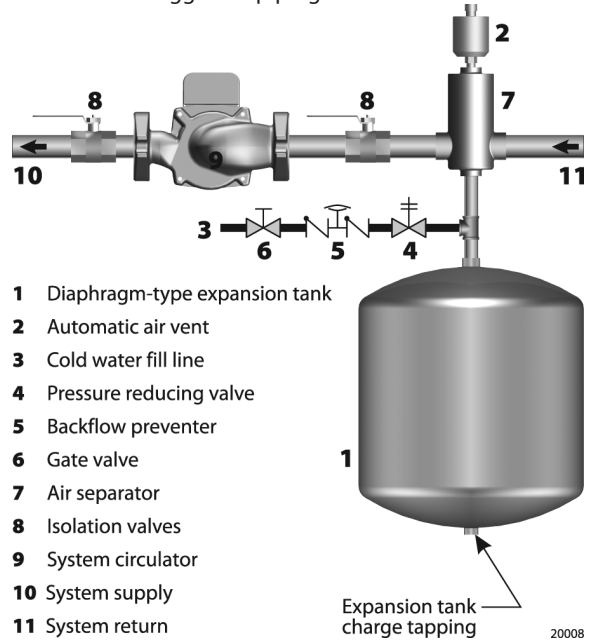

**Figure 7** Closed-type expansion tank suggested piping

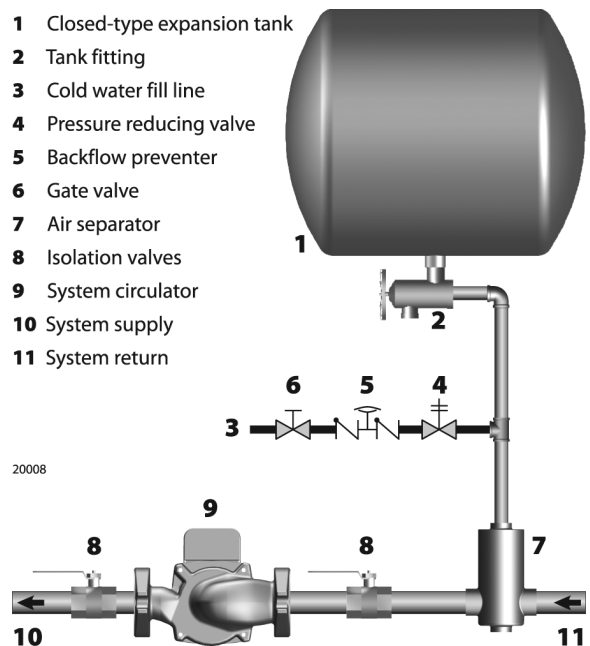

**CAUTION** Undersized or waterlogged expansion tanks will cause excessive make-up water to enter the system. This will lead to section failure due to oxygen corrosion and lime deposits.

**5**

**Water piping (continued)**

**Zoning with zone valves**

**Flow balancing and control**

On large systems, or when using a high-head circulator, install a differential pressure by-pass valve to limit the head applied to the zone valves.

Some systems may require balancing valves to control flow in the loops.

**DHW operation, when required**

The piping shown throughout this manual allows for domestic water heating without flow through the heating loop(s). This is important for summertime operation of DHW tanks.

Make sure to incorporate flow/check valves as shown. These prevent forced flow in idle zones.

**Figure 8** Suggested piping — single boiler — zone valve zoning — two-pipe or series loop (left), or primary/secondary piping (right)

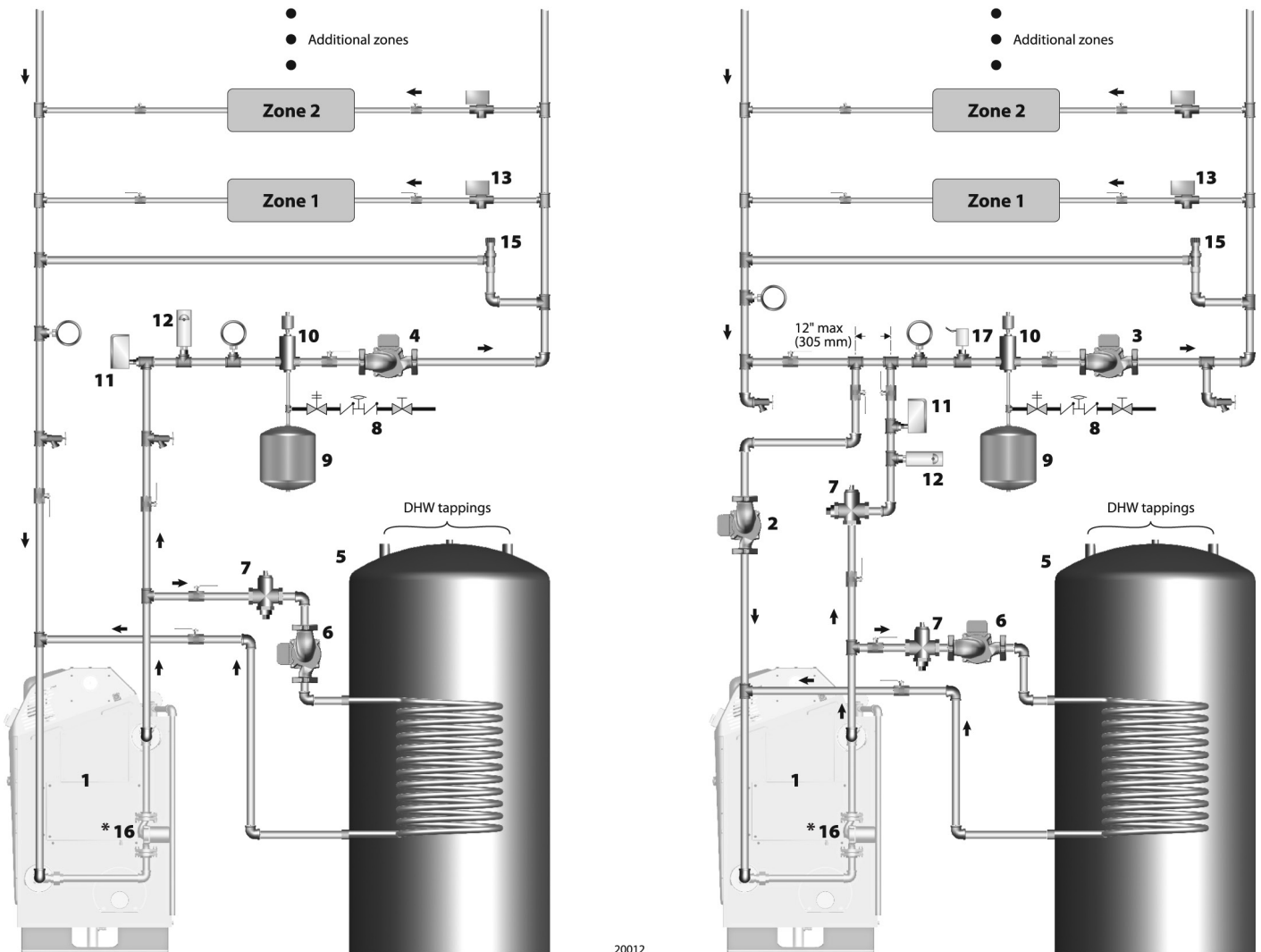

20012

**LEGEND** . . . . .

- 1 KN boiler
- 2 Boiler circulator
- 3 System circulator
- 4 Boiler/system circulator
- 5 Indirect-fired DHW tank (when used)
- 6 DHW circulator
- 7 Flow/check valve
- 8 Cold water fill line

- 9 Expansion tank (shown with diaphragm-type — see page 12 for piping a closed-type tank)
- 10 Air separator with automatic air vent (Replace air vent with piping to the tank fitting on closed-type expansion systems.)
- 11 Low water cut-off (when required)
- 12 Extra high limit (when required)
- 13 Zone valve
- 14 Zone circulator

- 15 Differential pressure by-pass valve — Use when high-head circulator may cause noise, erosion or valve lifting problems when only a few zone valves are open.
- \*16 Boiler postpurge circulator (see page 11) KN-2 only
- 17 Header sensor, required where shown
- Isolation valve
- Purge valve — Suggested locations allow for improved system filling and draining and initial air elimination.
- Temperature gauge



### 5

## Water piping (continued)

### Zoning with circulators

#### Sizing and flow control

Size circulators to provide the flow needed for the individual zones.

Provide flow/check valves where shown to prevent gravity circulation or forced flow in idle zones.

### DHW operation, when required

The piping shown throughout this manual allows for domestic water heating without flow through the heating loop(s). This is important for summertime operation of DHW tanks.

Make sure to incorporate flow/check valves as shown. These prevent forced flow in idle zones.

**Figure 9** Suggested piping — single boiler — circulator zoning — two-pipe or series loop (left), or primary/secondary piping (right)

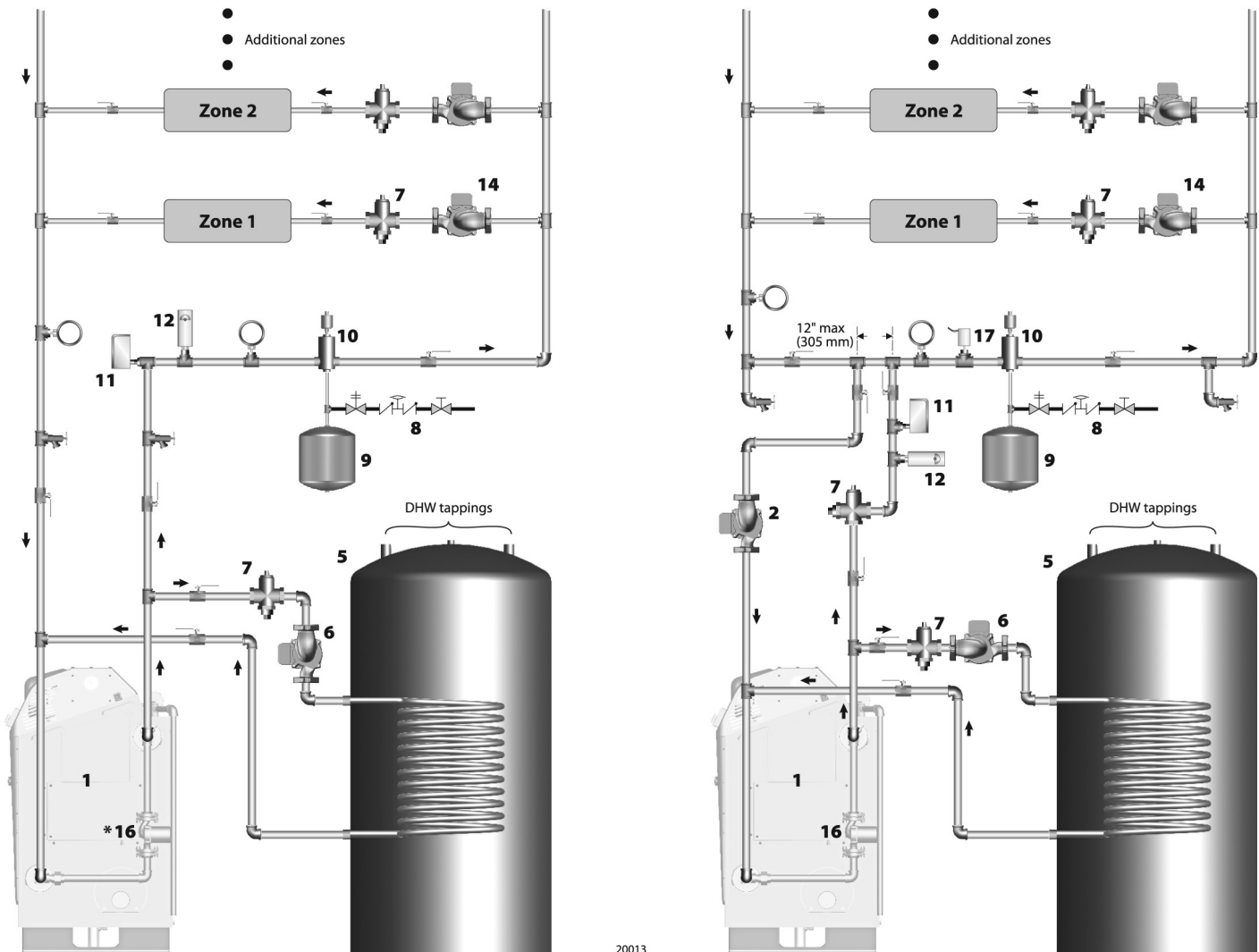

20013

#### LEGEND

- 1 KN boiler
- 2 Boiler circulator
- 4 Boiler/system circulator
- 5 Indirect-fired DHW tank (when used)
- 6 DHW circulator
- 7 Flow/check valve
- 8 Cold water fill line

- 9 Expansion tank (shown with diaphragm-type — see page 12 for piping a closed-type tank) Expansion tank (shown with diaphragm-type — see page 12 for piping a closed-type tank)
- 10 Air separator with automatic air vent (Replace air vent with piping to the tank fitting on closed-type expansion systems.)
- 11 Low water cut-off (when required)
- 12 Extra high limit (when required)
- 14 Zone circulator

\*16 Boiler postpurge circulator (see page 11) KN-2 only

17 Header sensor, required where shown

Isolation valve

Purge valve — Suggested locations allow for improved system filling and draining and initial air elimination.

Temperature gauge



### 5

## Water piping (continued)

### Multiple boilers, primary/secondary

#### Sizing and flow control

Size circulators to provide the flow needed for the individual zones.

Provide flow/check valves where shown to prevent gravity circulation or forced flow in idle zones.

### DHW operation, when required

The piping shown throughout this manual allows for domestic water heating without flow through the heating loop(s). This is important for summertime operation of DHW tanks.

Make sure to incorporate flow/check valves as shown. These prevent forced flow in idle zones.

**Figure 11** Suggested piping — multiple boilers — primary/secondary piping, reverse-return boiler headers

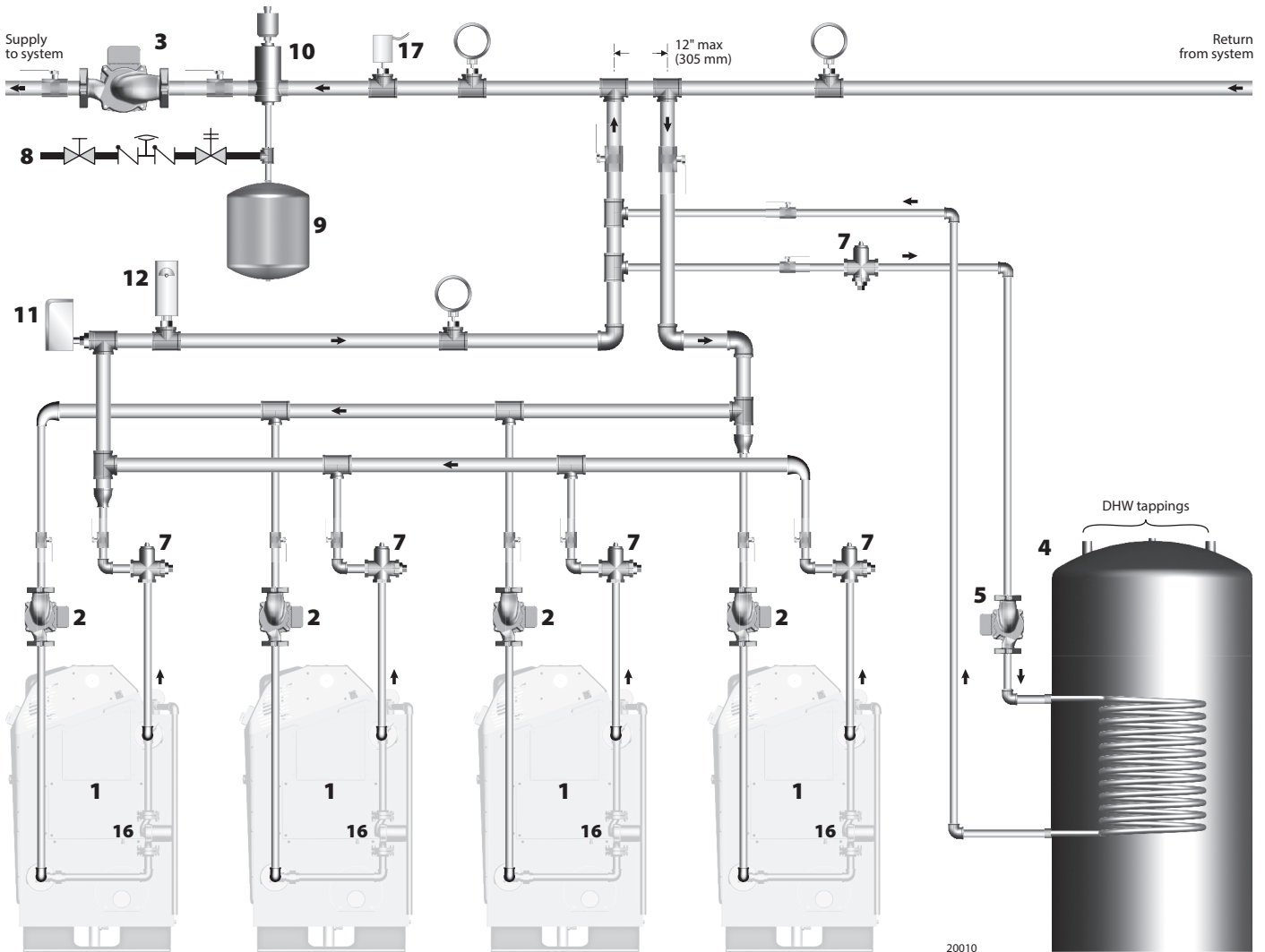

20010

#### LEGEND . . . . .

- 1 KN boiler
- 2 Boiler circulator
- 3 System circulator
- 5 Indirect-fired DHW tank (when used)
- 6 DHW circulator

- 7 Flow/check valve
- 8 Cold water fill line
- 9 Expansion tank (shown with diaphragm-type — see page 12 for piping a closed-type tank) Expansion tank (shown with diaphragm-type — see page 12 for piping a closed-type tank)
- 10 Air separator with automatic air vent (Replace air vent with piping to the tank fitting on closed-type expansion systems.)
- 11 Low water cut-off (when required)

- 12 Extra high limit (when required)
- 16 Boiler post-purge circulator (see page 11) KN-2 only
- 17 Header sensor, required
- Isolation valve
- Temperature gauge

**5**

**Water piping** *(continued)*

**Multiple boilers, parallel flow**

**Sizing and flow control**

Size the boiler/system circulator to handle the flow needs of all zones. If using variable speed control of the boiler/system circulator, ensure that the flow never drops below the total minimum for all boilers connected. Do not exceed the maximum flow of 50 GPM through any boiler.

**DHW operation, when required**

When heating system boilers are piped in parallel as in Figure 12, connect the DHW tank as a zone off of the main header or install boilers dedicated to the DHW application.

**Figure 12** Suggested piping — multiple boilers — parallel-flow piping, reverse-return headers

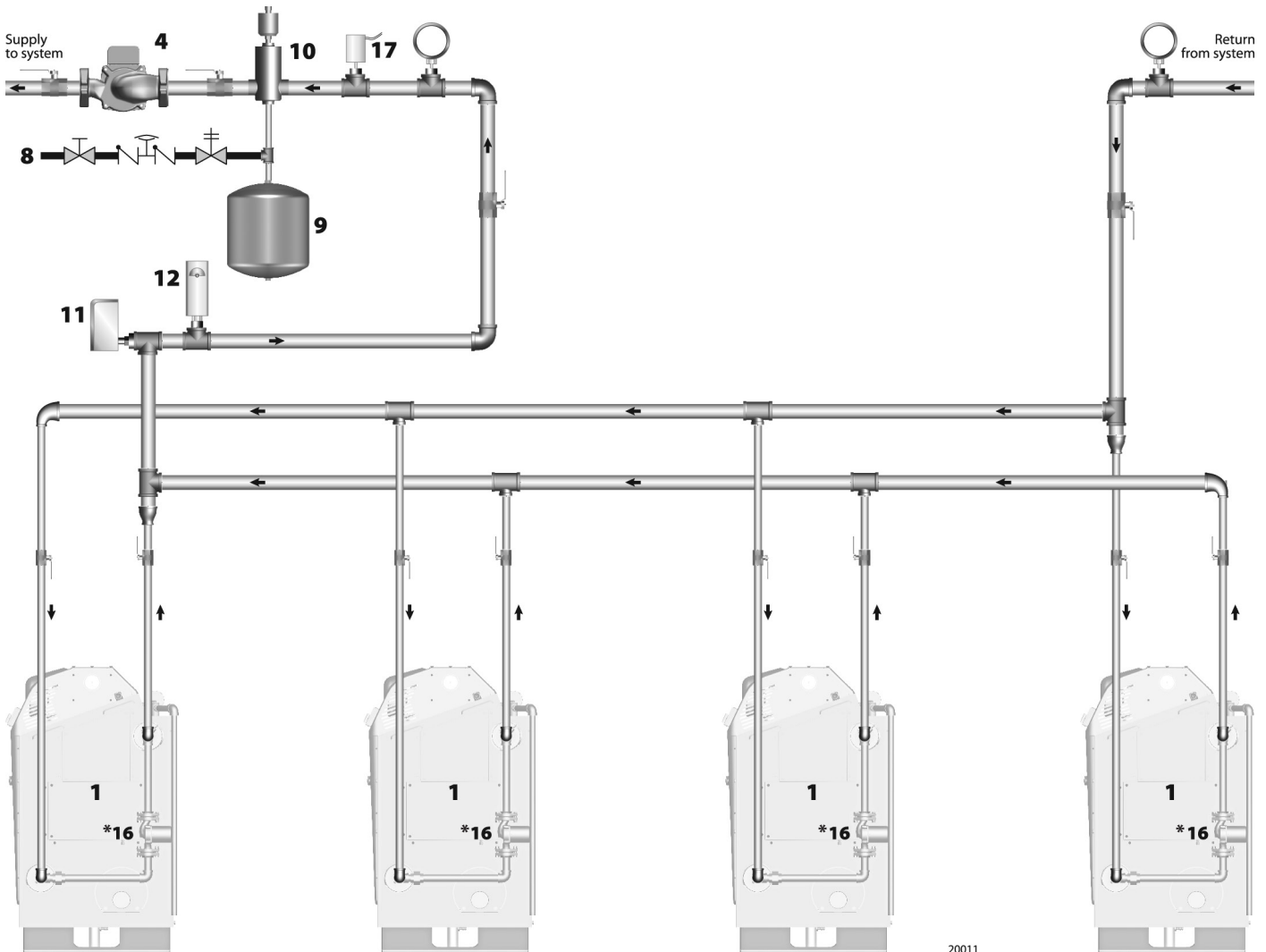



20011

**LEGEND** . . . . .

- 1** KN boiler
- 4** Boiler/system circulator
- 5** Indirect-fired DHW tank (when used)
- 6** DHW circulator

- 8** Cold water fill line
- 9** Expansion tank (shown with diaphragm-type — see page 12 for piping a closed-type tank) Expansion tank (shown with diaphragm-type — see page 12 for piping a closed-type tank)
- 10** Air separator with automatic air vent (Replace air vent with piping to the tank fitting on closed-type expansion systems.)
- 11** Low water cut-off (when required)

- 12** Extra high limit (when required)
- \*16** Boiler postpurge circulator (see page 11) **KN-2** only
- 17** Header sensor, required
-  Isolation valve
-  Temperature gauge

**5**

**Water piping** *(continued)*

**Chilled water systems**

**General**

Provide the piping components shown in Figure 13 when connecting a boiler to a chilled water system. The check valve (item 4) prevents chilled water from entering the boiler loop.

**Sizing and flow control**

Size the system circulator to handle the flow needs of all zones. If using variable speed control of the system circulator, ensure that the flow never drops below the total minimum for all boilers connected.

The boiler loop can be any of the designs in this manual, or per standard engineering practices.

Use the balancing valve to adjust the boiler loop flow.

**Expansion tank/air control**

Chilled water systems generally use closed-type expansion tanks. DO NOT use automatic air vents in these systems. All air must be return to the expansion tank for the system to operate reliably.

**CAUTION** If the boiler loop is connected to air handling units that use chilled water, install flow control devices to prevent gravity circulation in the boiler loop during the cooling cycle in the air handling units.

**Figure 13** Suggested piping — boilers connected to chilled water systems

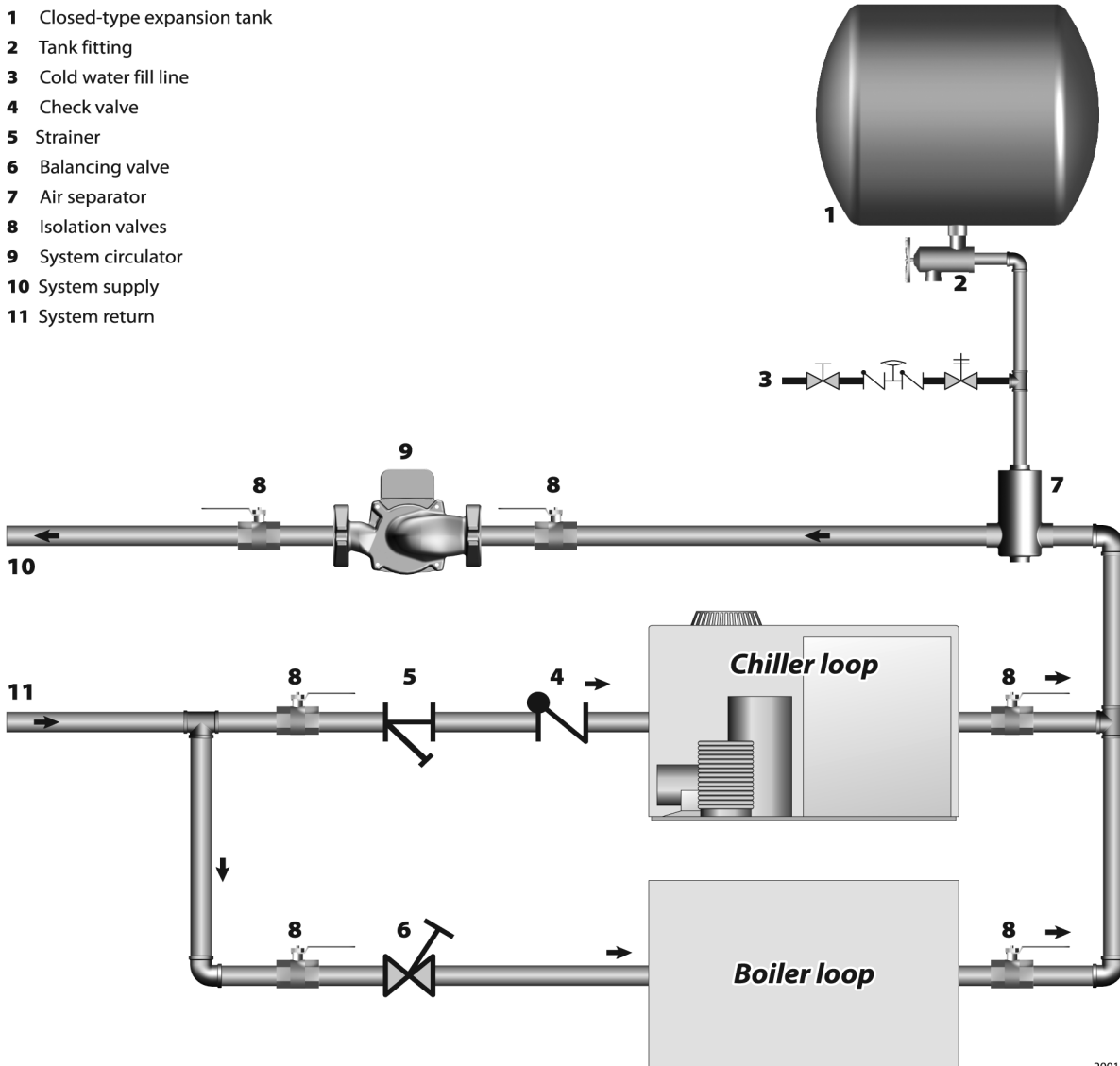

20014

### 6

## Gas piping

### Check the gas type

The KN comes from the factory ready to be piped to the gas supply. If for any reason the boiler is not for the type of gas available at the installation site, call your representative to resolve the problem. (See WARNING below.)

### Gas supply components

Figure 14 depicts the proper way to connect the boiler to the gas supply piping. The gas connection at the boiler is 1/2 inch NPT.

Item 1 — Install the gas line piping from the gas meter or branch in accordance with all applicable codes. See the next page for suggested sizing, or refer to the National Fuel Gas Code or Canadian Gas Code for recommendations.

Item 2 — The manual shut-off valve must be installed in the supply piping. Install 5 feet above the floor where required by applicable codes.

Item 3 — For all gas supply piping, use only clean, burr-free black iron pipe, supported independently from the boiler gas connection.

Item 4 — Install a ground-joint union in the gas line for ease of installation and servicing.

Item 5 — Provide a sediment trap at the bottom of the vertical section of the gas supply pipe upstream of the gas controls.

Item 6 — The gas cock must be equipped with a pressure test port. This test port is used to measure the gas supply pressure at the boiler.

The gas line components in Figure 14 are not supplied with the boiler. They must be supplied by the boiler installer.

**WARNING** Always use a wrench on the gas grain components when making gas connections. Never over-tighten the piping components or a failure could result, causing possible severe personal injury, death or substantial property damage.

**WARNING** Failure to adhere to the following could result in severe personal injury, death or substantial property damage.

#### Verify the gas type

Check the boiler rating plate to make sure that the boiler is for the type of gas that will be used. If it is not, do not connect the boiler to the gas supply.

#### Support the gas line

Support the gas line with hangers. DO NOT allow gas train weight to rest on or cause bending of the boiler gas connection fitting.

#### Protect the gas connection fitting

Use a 15/16 inch open-end wrench to hold the boiler gas connection fitting when tightening gas connection piping to the boiler.

#### Never leak test with flame

Never use an open flame to test for gas leaks. Always use an approved leak detection method.

#### Protect the boiler gas valve from excessive pressure

When pressure testing system gas piping, disconnect the gas piping from the boiler or isolate the boiler with the manual shut-off valve if test pressure will be higher than 1/2 psig (3.5 kPa).

**Figure 14** Connecting gas supply line

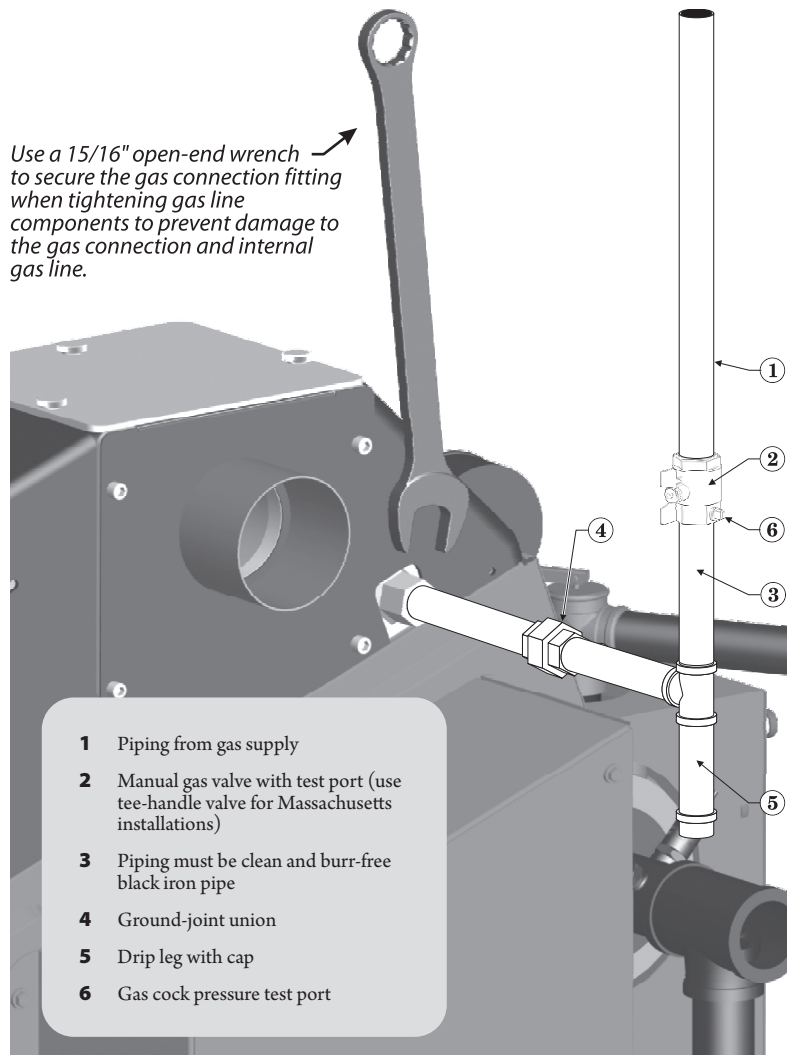

# 6

## Gas piping (continued)

### Gas piping joints

**⚠ WARNING** Always use a pipe sealant that is suitable for use with LP gas. Failure to comply could result in an explosion, causing possible severe personal injury, death or substantial property damage.

Only use pipe dope listed for use with propane gas. Even natural gas may contain some amount of propane.

Use pipe dope sparingly. Excessive pipe dope can block pipe flow or foul gas train components.

### Gas pipe sizing

#### Required supply pressure at boiler

Minimum gas supply pressure (natural gas or propane), both for flowing and static conditions:

2 inches (102 mm) water column.

Maximum gas supply pressure (natural gas or propane), both for flowing and static conditions:

14 inches (356 mm) water column.

#### Sizing guidelines

The sizing recommendations of Table 3 are taken from the National Fuel Gas Code, ANSI Z223.1/NFPA 54. Propane values are based on adjustment from propane specific gravity and pressure.

Table 3 allows for a pressure drop from the main supply regulator to the boiler of 0.3 inches (7.6 mm) water column for natural gas or propane.

For conditions not shown in Table 3, other pressure drops, or natural gas with other than 0.6 specific gravity, refer to the appropriate code guidelines for sizing.

#### Equivalent length

Do not neglect the pressure drop due to pipe fittings.

Equivalent length is the sum of the actual length of piping plus the total equivalent lengths of all fittings in the line from the main regulator to the boiler connection. See Table 4 for equivalent lengths of common fittings and components.

#### Multiple appliances

If more than one appliance is supplied by the same supply pipe, the piping must be sized based on the maximum possible demand.

**⚠ WARNING** Undersized gas supply piping can cause the gas line pressure to become negative during operation of the KN boiler. This can cause pilot outages and operation failures of other appliances connected to the line, including gas ranges, water heaters, etc. Failure to properly size the gas lines can result in potential for severe personal injury, death or substantial property damage.

**Table 3** Gas flow capacity for black iron pipe

Iron pipe size	Pipe length, equivalent feet (length plus allowance for fittings)								
	10	20	30	40	50	60	80	100	150
<b>Natural gas pipe flow capacity</b> (cubic feet per hour) (notes 1, 2, 3)									
¾"	278	190	152	130	115	105	90	79	64
1"	520	350	285	245	215	195	170	150	120
1 ¼"	1050	730	590	500	440	400	350	305	250
1 ½"	1600	1100	890	760	670	610	530	460	380
<b>Propane gas pipe flow capacity</b> (cubic feet per hour) (notes 2, 3)									
¾"	172	118	94	81	71	65	56	49	40
1"	320	220	175	150	135	120	105	95	75
1 ¼"	650	455	365	310	275	250	220	190	155

**Notes, Table 3**

1	Natural gas flow capacity is based on 0.60 specific gravity. Refer to the National Fuel Gas Code, ANSI Z223.1/NFPA 54, for other pressure drops and other specific gravity gases.
2	The flow rates above allow for a pressure drop of: Natural gas — 0.30 inches water column, with gas pressure 14 inches water column or less. Propane — 0.30 inches water column, with gas pressure 14 inches water column or less.
3	To determine required flow rate in cubic feet per hour for all appliances connected to the gas line: Natural gas — Divide total Btuh by the gas Btu per cubic foot rating (typically 1,000 Btu/ft <sup>3</sup> nominal). Propane — Divide total Btuh by 2,500.

**Table 4** Equivalent feet of pipe for common gas line components

Iron pipe size	Equivalent feet of pipe for each fitting			
	90° Elbow	Tee (note 1)	Gate valve (note 2)	Gas cock (note 2)
1"	2.6	5.2	0.6	1.5
1 1/4"	3.5	6.9	0.8	1.9
1 1/2"	4.0	8.0	0.9	2.3
2"	5.2	10.3	1.2	3.0

**Notes, Table 4**

1	Allows for flow through the branch of the tee.
2	Assumes valve is full open.

### Test all gas piping for leaks

**⚠ WARNING** All gas piping, components and connections must be leak tested before putting the boiler in operation. Isolate the boiler from the gas supply piping if testing with pressure greater than 14 inches (12.7 mm) pressure. Failure to do so could result in severe personal injury, death or substantial property damage.

Check all gas piping components and joints for leaks. Use either a soap suds mixture, a gas leak detector or other suitable means.

After testing the system gas piping, remove the gas valve cover plate on the left side of the boiler (see illustration at right). Inspect and leak test around the interior gas line and gas valve. Replace the cover after completing the gas connection inspection and testing.

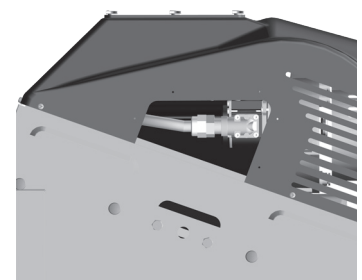



### 7

## Wiring a single boiler

**⚠️ WARNING Electrical shock hazard** — Disconnect all electrical power sources to the boiler before making any electrical connections.

Label all wires prior to disconnection when servicing controls. Wiring errors can cause improper and dangerous operation! Verify proper operation after servicing.

**⚠️ AVERTISSEMENT** Au moment de l'entretien des commandes, étiquetez tous les fils avant de les débrancher. Des erreurs de câblage peuvent entraîner un fonctionnement inadéquat et dangereux. S'assurer que l'appareil fonctionne adéquatement une fois l'entretien terminé.

Failure to comply with the above could result in severe personal injury, death or substantial property damage.

**NOTICE** The electrical connections to this boiler must be made in accordance with all applicable local codes and the latest revision of the National Electrical Code, ANSI /NFPA-70. Installation should also conform to CSA C22.1 Canadian Electrical Code Part I if installed in Canada. Install a separate 120 volt 15 amp circuit for the boiler. A properly rated shut-off switch should be located at the boiler. The boiler must be grounded in accordance with the authority having jurisdiction, or if none, the latest revision of the National Electrical Code, ANSI/NFPA-70.

Line voltage field wiring of any controls or other devices must use copper conductors with a minimum size of #14 awg. Use appropriate wiring materials for units installed outdoors.

### General

- The wiring and control information in the Boiler manual is targeted at single-boiler, stand-alone installations. For multiple boilers and advanced options, see the **KN** Control manual.
- See Figures 20 and 21 for a wiring summary. See the Control manual for content not covered in this manual.

### Power supply (120 VAC)

- See Figures 15 and 16.
- Connect minimum 14 awg copper wire to the power connection as shown in Figure 16.
- Install a fused service switch, mounted and installed in accordance with all applicable codes.

**Figure 15** Electrical connection board (see item 10, page 3 for location — Also see the wiring summary illustrations on the next pages)

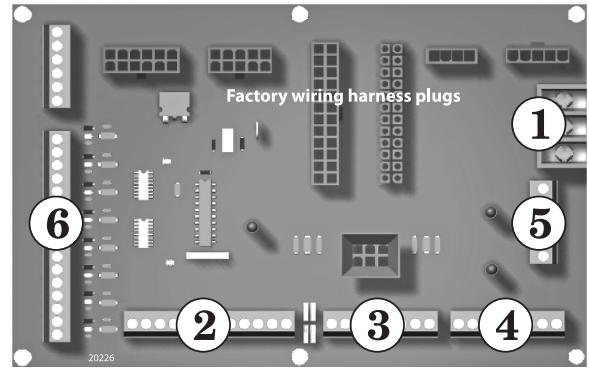

**Figure 16** 120VAC power service terminals on electrical connection board — See Figure 15 for location of the power terminal strip

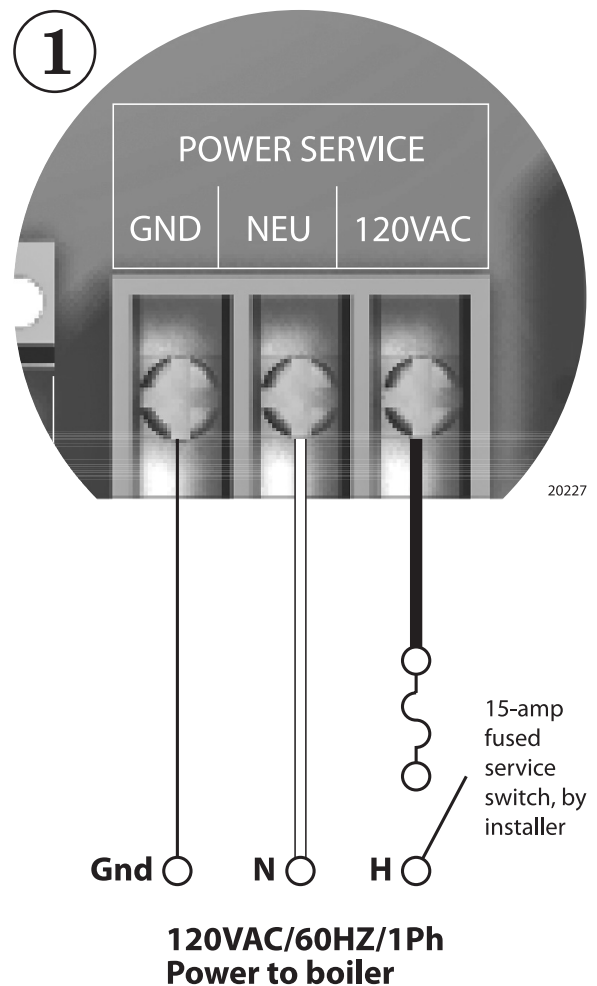

## Wiring single boiler *(continued)*

### Circulator wiring

#### Postpurge circulator

- The circulator shipped installed with the **KN-2 boiler cannot be used for system circulation.** It must be used as supplied from the factory. It circulates water after the boiler stops firing to prevent potential damage from heat pocketing in the top of the heat exchanger.
- The postpurge circulator is factory-piped and pre-wired. Do not change the usage, the wiring, the location or the piping.

#### Boiler circulator

- See section 5 of this manual for circulator piping.
- Figure 19 shows wiring of the Boiler circulator (or boiler/system circulator) to the terminal strip of the **KN** electrical connection board.
- **DO NOT** directly connect a circulator with a motor larger than 1/4 hp. For larger motors, install a circulator relay or motor contactor. Figures 17 and 18 show the correct ways to install the boiler circulator using a relay or motor starter.

**Figure 17** Wiring the boiler circulator using a circulator relay (required for motors over 1/4 hp)

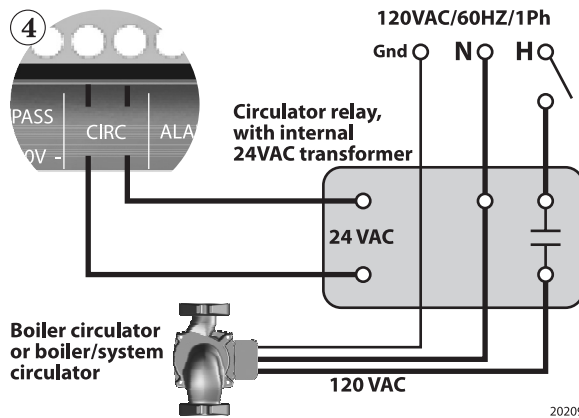

**Figure 18** Wiring the boiler circulator using a relay or starter (required for motors over 1/4 hp)

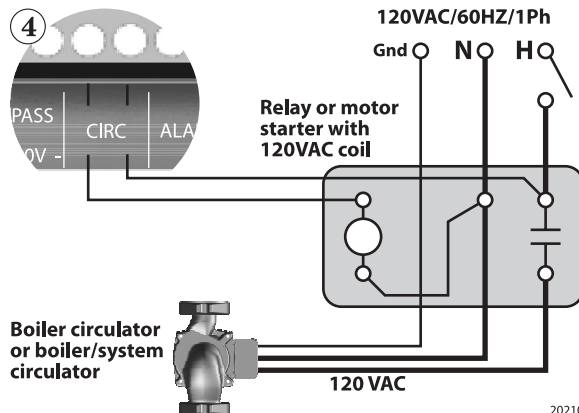

**Figure 19** Circulator wiring terminal strip (see Figure 15 for location) — Also see the wiring summary illustrations on the next pages)

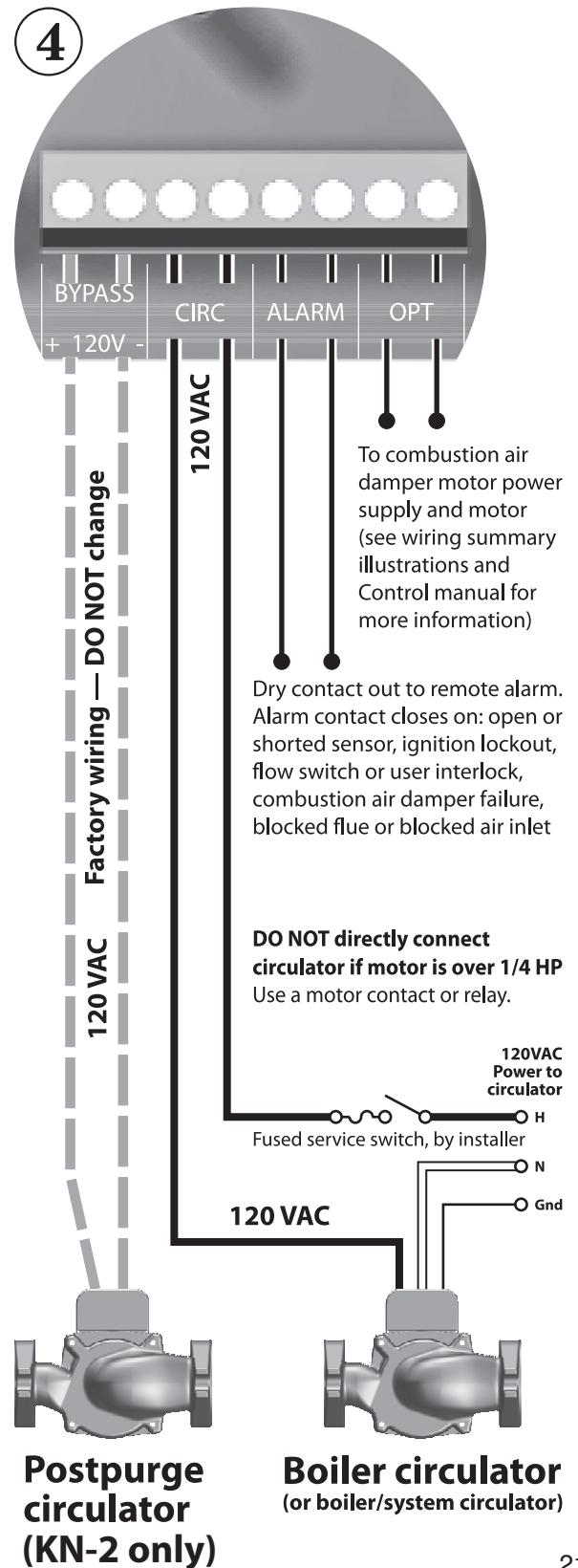

## Wiring single boiler *(continued)*

### Sensor wiring

No sensor wiring is necessary unless:

- **Outdoor reset application** — To operate with outdoor reset, purchase and install an outdoor sensor. Mount the sensor such that it is shielded from direct sunlight if possible and not likely to be covered by snow drifts or debris. Connect the outdoor sensor leads to the electrical connection board as shown in Figure 21b, page 24.
- **Header sensor application** — As shown in the piping diagrams in this manual, a header sensor is needed if the boiler supply temperature may be different from the header temperature. If required, purchase and install a header sensor in an immersion well. Locate the sensor where it will accurately sense the system water supply temperature. Connect the sensor leads to the electrical connection board as shown in Figure 21b, page 24.
- **Return water temperature sensor** — The return water temperature sensor is optional, only needed if you want to automatically control the boiler postpurge pump cycle time. To use the return water temperature sensor, purchase and install the sensor in a well in the boiler return piping. Connect the sensor leads to the electrical connection board as shown in Figure 21b, page 24.

### IAR (Indoor Air Reset) wiring, when used

- Heat Demand terminal connections — The end switch leads from the zone valves must connect to the Heat Demand terminals on the electrical connection board as shown in Figure 20 and Figure 21a.
- See Figure 20 for typical wiring to the IAR inputs when using 4-wire zone valves without a zone controller. For other applications, such as circulator relays or zone controllers, see Appendix A in this manual. Also see the Control manual.

**CAUTION** **Polarity** — The connections to the **IAR** positive terminals (**IAR +**) must be to the same location on the zone valve as the thermostat wire, as shown in Figure A1. The connections to the **IAR** negative terminals (**IAR -**) must be from the zone valve terminal connected to the 24VAC common line, as shown. Connecting the wires incorrectly can cause the transformer to be shorted out and damaged. Verify the wiring with a voltmeter.

**CAUTION** Always use a voltmeter to check the leads coming from the end switches of the zone valves. With the thermostat calling for heat, connect the voltmeter leads across the wires coming from the end switches. If the meter shows a voltage reading, the zone valve wires are incorrect. Change the wiring and retest. **DO NOT** connect the wires to the boiler until you have tested as described. Incorrect wiring can damage the boiler control or other system components.

- If there is only one transformer feeding all of the zone valves in the system, you can omit the wires to the **IAR** negative terminals (**IAR -**) on all but one of the zone valves. This is because these terminals are jumpered internally on the electrical connection board. If there is more than one transformer, provide one wire from each transformer common side to one of the **IAR** negative terminals (**IAR -**).

### DHW wiring

- To operate the boiler for domestic water heating with a storage tank, install and pipe the tank according to the tank manufacturer's instructions and the recommended piping diagrams in this manual. Consult the factory for applications not covered.
- The circulator used for DHW must be operated by a circulator relay or zone controller that is activated when the tank aquastat calls for heat.
- Connect the tank aquastat terminals across the DHW DEMAND terminals on the electrical connection board as shown in Figure 21.

**Figure 20** Indoor Air Reset wiring to IAR terminals with 4-wire zone valves and no zone controller (see Figure 21a for terminal block 6 location).

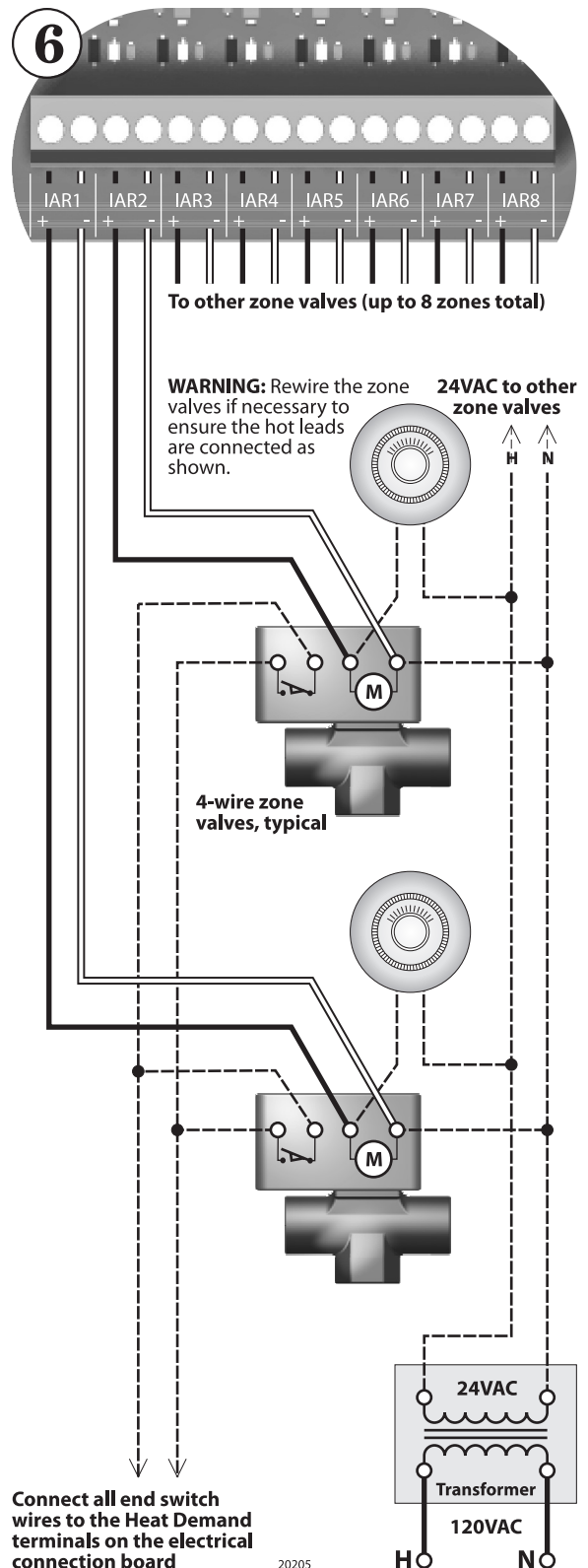

# Wiring and control setup *(continued)*

**Figure 21a** KN wiring summary (see Boiler manual and Control manual text for additional information)

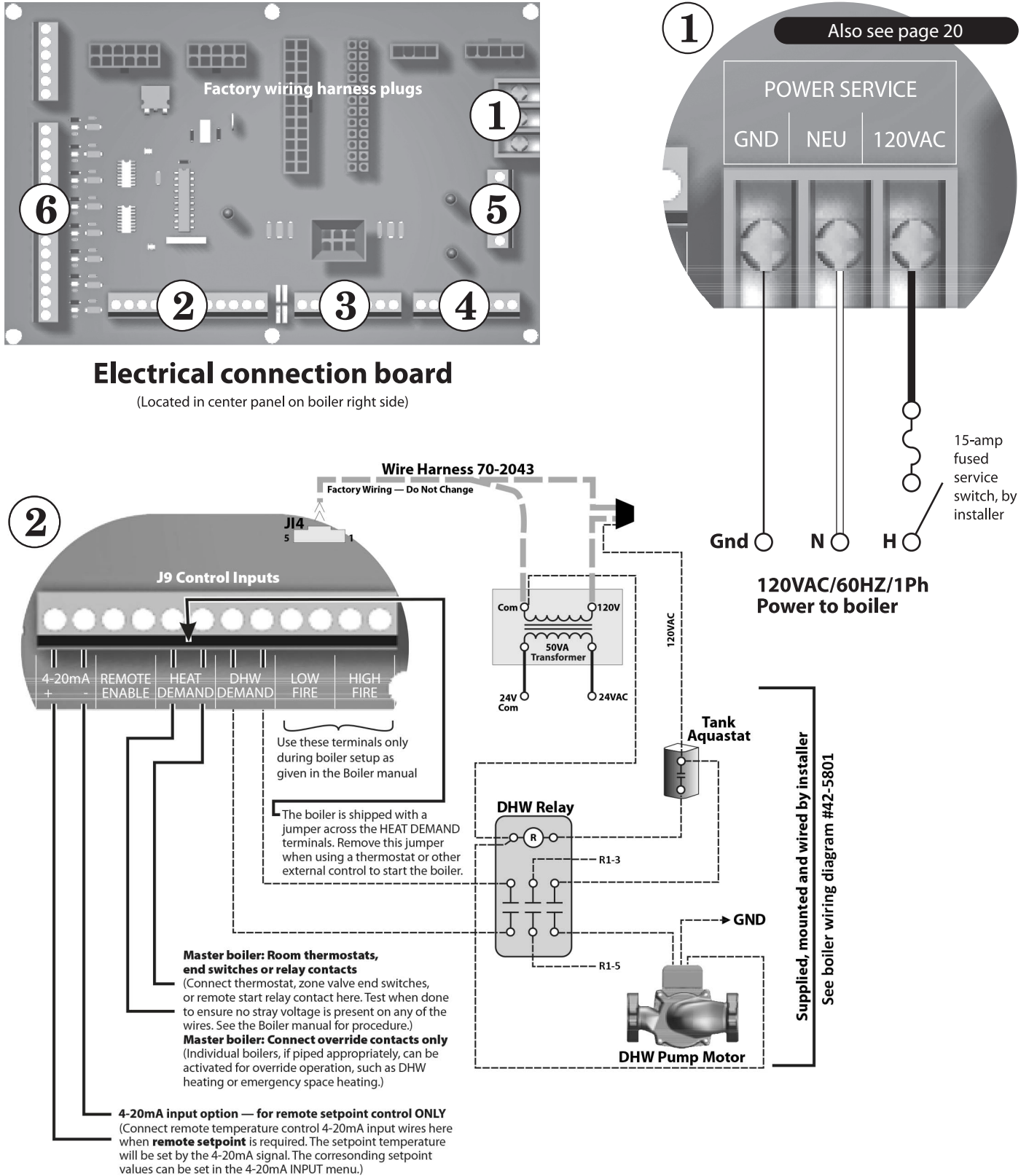

### 7

## Wiring and control setup *(continued)*

**Figure 21b** KN wiring summary (see Figure 21 for locations) (see Boiler manual and Control manual text for additional information)

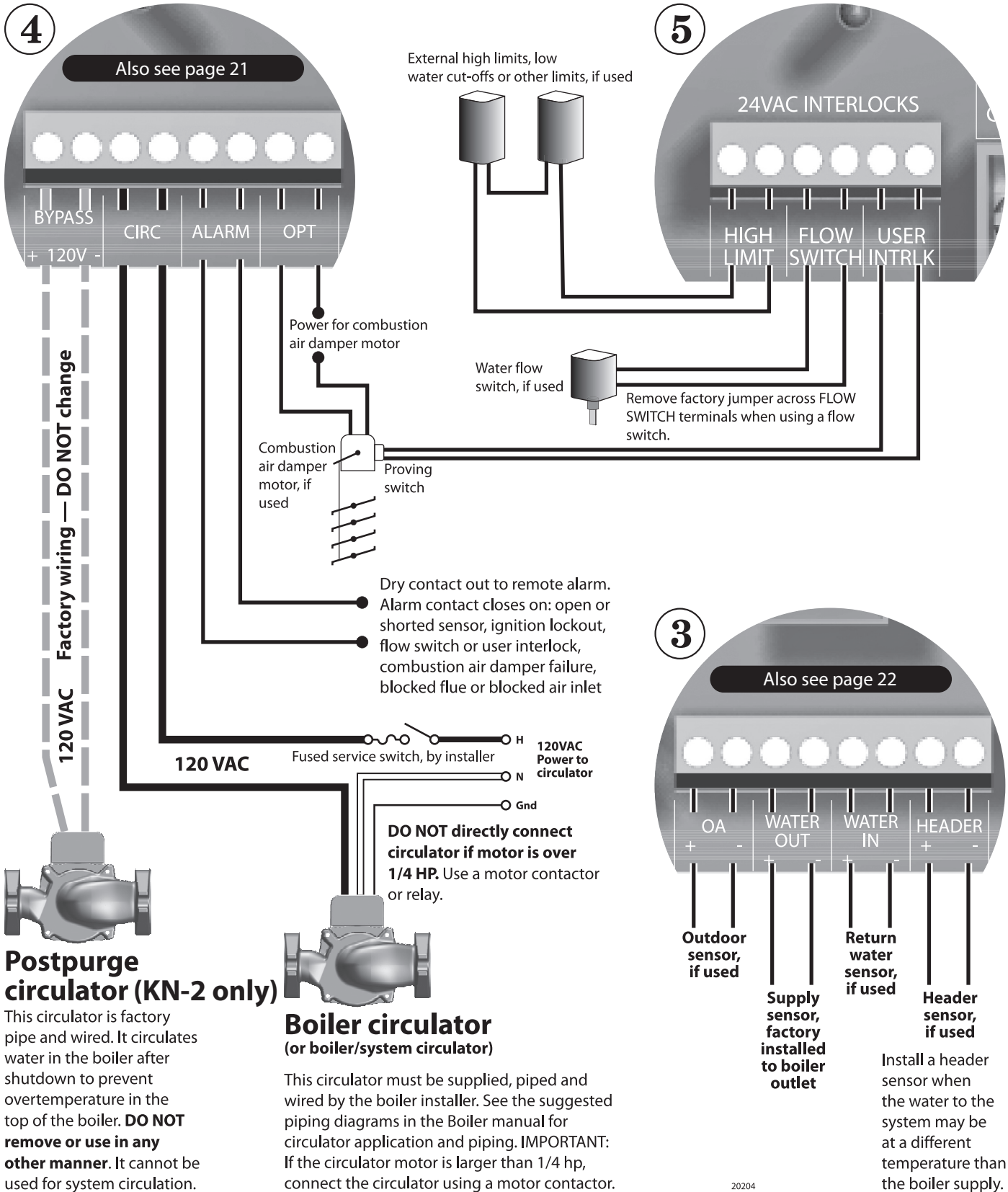

### Postpurge circulator (KN-2 only)

This circulator is factory pipe and wired. It circulates water in the boiler after shutdown to prevent overtemperature in the top of the boiler. **DO NOT remove or use in any other manner.** It cannot be used for system circulation.

### Boiler circulator (or boiler/system circulator)

This circulator must be supplied, piped and wired by the boiler installer. See the suggested piping diagrams in the Boiler manual for circulator application and piping. **IMPORTANT:** If the circulator motor is larger than 1/4 hp, connect the circulator using a motor contactor.



8

# Control setup

## Before control setup

**CAUTION** Before beginning the HeatNet control setup, **remove the wires connected to the HEAT DEMAND and DHW DEMAND terminals** on the electrical connection board (see Figure 21). These must be removed to prevent a call for heat during the setup process.

Close the manual gas valve before proceeding to prevent any possibility of the boiler firing during setup.

## The HeatNet control display

### Starting the display

1. Check all wiring to make sure it is complete and all wires are securely connected.
2. Verify that the HEAT DEMAND and DHW DEMAND wires are removed.
3. Turn on power to the boiler and then turn the boiler on/off switch ON.
4. The control will beep at least twice and the display will show the first STANDBY display in Figure 22. Note that pushing the DOWN button on the keypad will change the right side of the display as shown, providing information on various setpoints and parameters.
5. The display, LOC SET, means the setpoint temperature. Figure 22 shows the factory default values.

### Accessing setup menus

1. With the display in STANDBY, press and hold the BACK key for 5 seconds.
2. The display will change to:



3. Press the SELECT key to select setup. (Note that pressing the DOWN key would change the selection to VIEW LOG.)
4. The display will now show the first options in the setup menus:



5. Press the DOWN key to access additional menu options. Pressing the DOWN button once will change the display to:



6. The cursor moves to the second line, indicating this option could now be selected with the SELECT key.
7. Continuing to press the DOWN key will access these menu options:
  - BOILERS
  - SETPOINTS
  - INDOOR AIR
  - PUMP OPTIONS
  - NIGHT SETBACK
  - OPTIONS
  - LOG/RUNTIME
  - AUX FUNCTIONS
  - SYSTEM CLOCK
  - ADVANCED SETUP

**Figure 22** HeatNet display during Standby (no call for heat) — pressing the DOWN key on the keypad changes the display as shown



## Control setup *(continued)*

### Recommended settings

1. The following recommendations should cover most single-boiler applications.
2. The settings covered in this manual are SETPOINTS, INDOOR AIR, OUTDOOR AIR and SYSTEM CLOCK.
3. For other settings and a complete menu tree, consult the **KN** Control manual for information.

### Adjust SETPOINTS

#### Setpoint menus

1. Use the arrow keys until the cursor points at SETPOINTS.
2. Press the SELECT button to enter the SETPOINTS menus. The menu selections available as you use the arrow keys will be:
  - **LOC SETPOINT** (means the local setpoint, or the target temperature of the boiler supply water; this is sensed by the SUPPLY sensor).
  - **SOURCE** (means whether the setpoint temperature is to be controlled at the boiler or by a remote device — leave the default setting of AUTO unless you plan to use a remote controller with a 4-20ma output).
  - **DHW SETPOINT** (means the supply temperature the boiler will target when operating on a call for DHW heating; this uses the same sensor as the local setpoint).
  - **OP LIMIT** (means the operating limit temperature of the boiler).
  - **LIMIT BAND** (this is the differential for the limit function).

#### Set the local setpoint (LOC SETPT)

1. Use the arrow keys until the cursor points at LOC SETPT. The display will show:

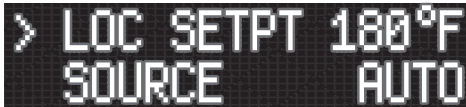

2. The cursor must be pointing at LOC SETPT. The value shown may vary if the control has been adjusted before.
3. Press the SELECT button to change the local setpoint value.
4. The cursor will move to the temperature number.
5. Use the arrow keys to increase or decrease the temperature to the desired setting.

**NOTICE** If you hold down the arrow key the numbers will change faster after a brief waiting period.

6. When the setting is correct, press the SELECT key to accept. Then press the BACK key to leave the local setpoint adjustment.
7. The local setpoint should be set at the design water temperature for the heating units (typically 180°F for finned-tube baseboard, for example).

**NOTICE** The setpoint must never be higher than the OP LIMIT setting minus the LIMIT BAND minus half of the HEAT BAND setting. This would cause the boiler to hit limit while trying to modulate.

Example: If LIMIT BAND is 20°F, OP LIMIT is 215°F, and HEAT BAND is 30°F, the local setpoint must never be higher than  $215 - 20 - 30/2 = 180^\circ\text{F}$ .

#### Set the DHW setpoint (DHW SETPT)

1. Skip this procedure if the boiler is not used for DHW heating.
2. Use the arrow keys until the cursor is at DHW SETPT. The display will be:



3. With the cursor on DHW SETPT, press the SELECT key to change the value, using the same procedure as with the LOC SETPT adjustment.
4. The DHW setpoint should usually be 190°F. To obtain this setpoint, you will also have to increase the OP LIMIT setting to 225 or 230°F so the boiler won't prematurely cycle on the limit function.
5. When the DHW setting is complete, press SELECT and BACK to return to the setpoint menus.

#### Set OP LIMIT (operating limit)

1. Use the same procedure as on the previous settings to change the operating limit temperature.
2. Use the arrow keys to select OP LIMIT, then press SELECT.
3. If the boiler setpoint is to be higher than 180°F, you will need to increase OP LIMIT. The maximum setting for OP LIMIT is 230°F. So the maximum allowable boiler setpoint is generally 190°F.
4. Once the setting is correct, press SELECT, then BACK to return to the setpoint menus.

#### The LIMIT BAND

1. Do not change the LIMIT BAND setting unless specific application demands require a change or when directed by the factory.

#### Return to main menus

**NOTICE** When the setpoints have all been adjusted as desired, press the BACK key until you return to SETPOINTS.

### INDOOR AIR

#### General

- Use the indoor air reset option whenever possible. The indoor air technology monitors space heating demand to help the boiler operate at the highest possible efficiency throughout the season.
- To apply indoor reset you must wire the IAR inputs and the HEAT DEMAND terminals as described in Section 7.

#### Enable or disable IAR

1. The only setting for indoor air reset that you will need to make is to enable the function.
2. Use the arrow keys until the cursor points to **INDOOR AIR**.
3. Press SELECT to enter the indoor air menus.
4. The display will show:

## Control setup *(continued)*



- The factory default setting is ON, or IAR enabled. If the boiler is wired for IAR, then leave the setting at ON.
- To change the setting to off, press SELECT with the cursor pointing at IA RESET.
- Press either arrow key and the value will change to OFF.
- Press SELECT to save and BACK to return to the main menus (INDOOR RESET again).

### Return to main menus

**NOTICE** When you have finished with IAR, return to the main menus by using the BACK key.

## OUTDOOR AIR, when used

### General

**NOTICE** Skip this procedure if there is no outdoor sensor present.

- When possible, use Indoor Air Reset instead of outdoor reset. IAR provides much better feedback on system needs.

### OUTDOOR AIR menu

- Use the arrow keys until the cursor points at OUTDOOR AIR. Then press SELECT.
- The display will show the beginning of the OUTDOOR AIR menus:



- OUTDOOR AIR menus are:
  - OA SHUTDOWN** (shuts the boiler down when outside temperature is above OA SETPT).
  - OA SETPOINT** (outside temperature at which no heat is needed — used to shut down boiler above this temperature).
  - OA RESET** (enables or disables outdoor reset function).
  - SET OA SETPTS** (when outdoor reset is enabled, this leads to setpoint selections).

### Outdoor shutdown

- Enable or disable outdoor shutdown by pressing the SELECT button with the cursor on OA SHUTDOWN.
- Use the arrow keys to change from ON to OFF.
- Press SELECT to save, then BACK to return.
- Then arrow key to OA SETPT to set the desired outdoor air shutdown temperature.
- Press SELECT and the cursor will move to the temperature.
- Use the arrow keys to change the setting.
- Press SELECT, then BACK to accept and return.

### Outdoor reset, when desired

- To set outdoor reset operation, use the arrow keys until the cursor points at OA RESET.

- The default setting is ON.
- To change the setting, press SELECT and use the arrow keys to change from ON to OFF.
- Press SELECT, then BACK.
- If outdoor reset is enabled, set the reset temperatures as follows:
- Use the arrow keys until the cursor points at SET OA SETPTS.
- Press SELECT and the display will show:



- Don't use the arrow keys yet, but if you use the DOWN arrow twice, the display will show:



- With the cursor on the setting you want to change, press the SELECT key, then use the arrow keys to change the temperature as you did for SETPOINTS.
- LOW WATER (@ HI OA) — Set for the supply water temperature desired when the outside air is at the temperature when no heat is needed (HI OA). This should generally be set equal to room temperature, or 70°F unless the application calls for another setting.
- HI OA — Set this to the outside temperature at which no heat is needed, usually 68°F or lower.
- HI WATER (@LO OA) — This is the required supply water temperature at design heating conditions; i.e. when outside air temperature is at ODT, the outdoor design temperature, or maximum heating conditions. This temperature would typically be 180°F for finned-tube baseboard systems.
- LO OA — This is the ODT, or design outdoor temperature for maximum heating requirements from the system.
- Use the arrow keys to navigate to each of the above. Then adjust as required.

### Return to main menus

**NOTICE** When you have finished with outdoor reset, return to the main menus by using the BACK key.

## Set the system clock

- Use the arrow keys in the main menus to navigate to **SYSTEM CLOCK**. Use the procedures used for SETPOINTS and other adjustments to select and modify **TIME, DAY OF WEEK, MONTH, DAY and YEAR**.
- Because the events log gives time of occurrence, it is best for the system clock to be correct.

**NOTICE** After completing setup, press the BACK key until the display returns to STANDBY. Then turn off power and the boiler on/off switch. Reconnect HEAT DEMAND and DHW DEMAND wires.

## Vent piping (and air piping when used)

All **KN** boilers must be vented using only the materials listed in the **KN** Vent/Air manual. The vent installation must meet requirements for direct vent (when air is ducted to the boiler air intake) or ANSI Category IV venting (when air is taken from the boiler room).

**⚠WARNING** DO NOT install a **KN** boiler on a common vent system. All **KN** boilers must be individually vented. Failure to comply could result in improper operation of any of the appliances on the vent system, resulting in possible severe personal injury, death or substantial property damage.

When a **KN** boiler replaces a boiler that shared a common vent system, follow the guidelines below to check operation of the remaining appliance(s). Consult factory when common venting multiple boilers and/or use an engineered venting system solution.

**BEFORE PROCEEDING FURTHER** — Install the vent (and air) piping according to the **KN** Vent/Air manual.

### Common vent systems

If an existing boiler is removed from a common venting system, the common venting system may then be too large for the proper venting of the remaining appliances connected to it. At the time of removal of an existing boiler, the following steps shall be followed with each appliance remaining connected to the common venting system placed in operation, while the other appliances remaining connected to the common venting system are not in operation.

1. Seal any unused openings in the common venting system.
2. Visually inspect the venting system for proper size and horizontal pitch and determine there is no blockage or restriction, leakage, corrosion and other deficiencies which could cause an unsafe condition.
3. Insofar as is practical, close all building doors and windows and all doors between the space in which the appliances remaining connected to the common venting system are located and other spaces of the building. Turn on clothes dryers and any appliance not connected to the common venting system. Turn on any exhaust fans, such as range hoods and bathroom exhaust, so they will operate at maximum speed. Do not operate a summer exhaust fan for a boiler installation. Close fireplace dampers.
4. Place in operation the appliance being inspected. Follow the lighting instructions. Adjust thermostat so appliance will operate continuously.
5. Test for spillage at the draft hood relief opening after 5 minutes of main burner operation. Use the flame of a match or candle, or smoke from a cigarette, cigar or pipe.
6. After it has been determined that each appliance remaining connected to the common venting system properly vents when tested as outlined above, return doors, windows, exhaust fans, fireplace dampers and any other gas-burning appliance to their previous condition of use.
7. Any improper operation of the common venting system should be corrected so the installation conforms with the National Fuel Gas Code, ANSI Z223.1/NFPA 54. When resizing any portion of the common venting system, the common venting system should be resized to approach the minimum size as determined using the appropriate tables in Appendix F in the National Fuel Gas Code, ANSI Z223.1/NFPA 54 and or CSA B149 Installation Codes.

### Systèmes d'évacuation d'communs

Au moment du retrait d'une chaudière existante, les mesures suivantes doivent être prises pour chaque appareil toujours raccordé au système d'évacuation commun et qui fonctionne alors que d'autres appareils toujours raccordés au système d'évacuation ne fonctionnent pas: système d'évacuation

1. Sceller toutes les ouvertures non utilisées du système d'évacuation.
2. Inspecter de façon visuelle le système d'évacuation pour déterminer la grosseur et l'inclinaison horizontale qui conviennent et s'assurer que le système est exempt d'obstruction, d'étranglement de fuite, de corrosion et autres défaillances qui pourraient présenter des risques.
3. Dans la mesure du possible, fermer toutes les portes et les fenêtres du bâtiment et toutes les portes entre l'espace où les appareils toujours raccordés au système d'évacuation sont installés et les autres espaces du bâtiment. Mettre en marche les sècheuses, tous les appareils non raccordés au système d'évacuation commun et tous les ventilateurs d'extraction comme les hottes de cuisinière et les ventilateurs des salles de bain. S'assurer que ces ventilateurs fonctionnent à la vitesse maximale. Ne pas faire fonctionner les ventilateurs d'été. Fermer les registres des cheminées.
4. Mettre l'appareil inspecté en marche. Suivre les instructions d'allumage. Régler le thermostat de façon que l'appareil fonctionne de façon continue.
5. Faire fonctionner le brûleur principal pendant 5 min ensuite, déterminer si le coupe-tirage déborde à l'ouverture de décharge. Utiliser la flamme d'une allumette ou d'une chandelle ou la fumée d'une cigarette, d'un cigare ou d'une pipe.
6. Une fois qu'il a été déterminé, selon la méthode indiquée ci-dessus, que chaque appareil raccordé au système d'évacuation est mis à l'air libre de façon adéquate. Remettre les portes et les fenêtres, les ventilateurs, les registres de cheminées et les appareils au gaz à leur position originale.
7. Tout mauvais fonctionnement du système d'évacuation commun devrait être corrigé de façon que l'installation soit conforme au National Fuel Gas Code, ANSI Z223.1/NFPA 54 et (ou) aux codes d'installation CSA-B149. Si la grosseur d'une section du système d'évacuation doit être modifiée, le système devrait être modifié pour respecter les valeurs minimales des tableaux pertinents de l'appendice F du National Fuel Gas Code, ANSI Z223.1/NFPA 54 et (ou) des codes d'installation CSA-B149.



# 10

## Condensate drain line

### Fill the condensate trap

Before installing the condensate line, you must fill the condensate trap with water. This will prevent flue products from escaping into the room. To fill the trap:

- Temporarily attach a 3/8 inch clear plastic hose to the condensate hose barb (see Figure 23).
- Attach a funnel to the other end of the hose and hold the funnel so it is higher than the hose barb.
- Pour water into the funnel until water backs up into the tube.
- Remove the temporary plastic hose.

**WARNING** The condensate trap must be filled when firing the boiler to prevent flue gases from escaping into the room.

### Condensate line installation

#### Condensate tubing material

The condensate tubing must be silicone rubber, 3/8 inch (9.5 mm) diameter.

#### Attachment

Feed the silicone rubber tubing through the condensate line exit opening and slide the tubing end onto the condensate line hose barb as shown in Figure 23.

#### Securing/protecting the condensate line

**Secure the tubing** — Secure the condensate line to the floor with clips or other means to prevent movement.

**Protect tubing from damage** — If foot traffic poses a risk to the tubing, install a cover over the tubing, or some other means to protect it from damage or movement.

**Prevent freezing** — Do not route the line through, or terminate the line in, any area that could expose the condensate to freezing temperatures.

#### Floor drain termination

If the condensate line can be routed to a floor drain, and applicable codes do not prohibit draining untreated condensate, terminate the condensate line so condensate can reliably flow to the drain.

#### Condensate pump termination

If no gravity drain is available, install a condensate pump. Use only a pump designed for use with condensing furnaces and boilers. The pump must have an overflow switch to prevent damage from overflowing condensate. Wire the switch into the boiler limit circuit. See the **KN** Control manual for details.

#### Neutralization

When required by codes or preference, install an appropriate condensate neutralization system.

### Condensate line requirements

**WARNING** Failure to adhere to the following could result in condensate line leakage, resulting in potential for severe personal injury, death or substantial property damage.

- Use only silicone rubber tubing, 3/8 inch (9.5 mm) diameter.
- Protect the condensate line from damage and secure it in position.
- Terminate the condensate line at an appropriate drain.
- Do not install the condensate drain line such that it could be exposed to freezing temperatures.
- Install a condensate pump if no appropriate drain is available.
- Install a condensate neutralizing system when required.

**Figure 23** Condensate drain line connections (KN-2 shown — J-trap configuration is the same for KN-4, but mounted directly to a clamping bracket on the U-channel)

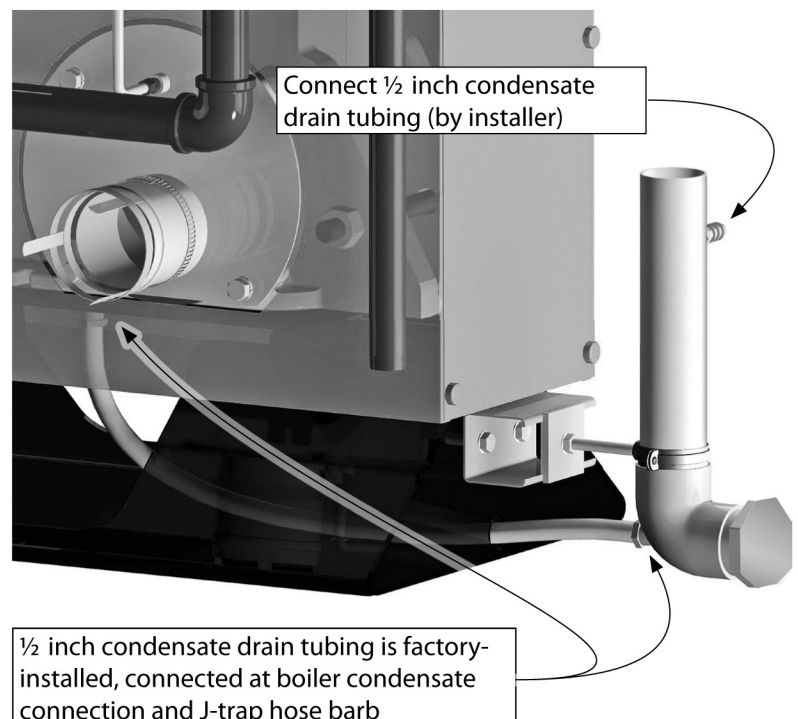



**11****Fill and test the system**

**⚠ WARNING** Failure to adhere to the following could result in boiler section failure, resulting in potential for severe personal injury, death or substantial property damage.

- Flush and clean the system before filling.
- Provide clean water to fill the system
- Water quality must be as prescribed in this manual.

**Follow the system water checklist**

Follow the guidelines in this section to fill and test the system. The system water quality must meet the conditions given, and you and the owner must make sure the conditions will be maintained throughout the life of the boiler.

 **Closed systems only**

- Do not apply the **KN** boiler on open systems, such as direct heating of domestic water, swimming pool heating or process applications that use system water. For these applications, you must install a heat exchanger.

 **Hard water conditions**

- If water hardness exceeds 7 grains, use a water softener in the fill line to soften the water before it enters the system.
- On multiple boiler commercial installations, the large volume of water in the system can contain substantial mineral salts, even if the fill water hardness is less than 7 grains. These salts can deposit in the boiler heat exchanger as limestone, causing possible section damage. Commercial installations should usually be filled with soft water to avoid this problem.

 **Prevent oxygen corrosion**

- Make sure the system is provided with adequate automatic air elimination, including an in-line air separator and automatic air vents (diaphragm or bladder tank systems) or piping to the expansion tank (closed-type expansion tank systems).
- Do not connect the **KN** boiler to a system that contains non-barrier radiant tubing. Non-barrier tubing can allow oxygen to enter the system, causing oxygen corrosion of the boiler heat exchanger.

 **Flush and clean the system**

- Flush the system to remove sediment, flux, filings and other foreign matter. Use cleaning chemicals sold for use in hydronic systems.
- Replacement boiler installations often have large amounts of accumulated sediment and corrosion that must be removed to ensure boiler life and reliable operation.
- Flush each zone of multi-zone systems individually using the purge valves and isolation valves in the system.
- Flush until the water runs clean.

- After flushing the system thoroughly, use trisodium phosphate or other chemical sold for cleaning hydronic systems to remove sediment and sludge.

**⚠ WARNING** Use caution when working with chemicals, following all guidelines specified by the chemical supplier and the applicable codes.

 **Purge air from the system**

- The system should be installed with purge valves such as those shown in the suggested piping in this manual. Purging is the most efficient way to fill the system and remove most of the air.
- Connect a hose to a purge valve and run the hose to an appropriate draining area. (When filling with antifreeze solution, run the hose back to the solution tank.)
- Close all isolation valves in the system.
- Open the manual valve (or quick-fill valve) on the make-up water line. (When filling the system with glycol, connect from the glycol pump to one of the purge valves with a hose.)
- Purge each zone separately by opening the isolation valves for that zone, allowing water to push the air through and fill the zone. After filling the zone, close the isolation valves and move to the next zone.
- Fill and purge the boiler loop in the same manner.
- After the boiler is operated for a while, air entrained in the fill water will bubble out of the water as it heats, and will have to be removed by using air vents in the system.

 **Add a chemical inhibitor**

- After purging and filling the system, add a chemical inhibitor sold for use in hydronic systems to prevent limestone and magnetite deposits from forming, and to protect the boiler from galvanic corrosion.

 **Water pH**

- The boiler water must be slightly basic, never acidic. Use litmus paper to check pH, which should range from 6.5 minimum to 11 maximum.
- If pH does not comply, provide water chemistry correction from a qualified water treatment specialist. If required, make sure that the owner is aware and that the regimen will be continued.

## Fill and test the system *(continued)*

### ❑ Antifreeze

- Antifreeze for hydronic systems contains propylene glycol and an inhibitor. Without the inhibitor the glycol is actually corrosive. So the system water must be checked at least annually to ensure that the inhibitor is at the correct level.
- **Never** use galvanized piping in a system that contains antifreeze. Never use chromate water treatment. Either of these will react with the inhibitor in the antifreeze mix.
- **Antifreeze concentration** — If not using a pre-mixed antifreeze solution, determine the amount of antifreeze to add based on the total volume of the system piping, the boiler and the expansion tank. Follow the antifreeze manufacturer's instructions for the ratio of glycol required for the lowest expected exposure temperature. NEVER use a glycol mix greater than 50%.
- **Prevent leaks** — Glycol will escape more easily than water through any leak in the system. So the glycol concentration will reduce if a leak is allowed to continue. Eliminate all leaks in the system and have the owner frequently inspect the visible portions of the system for leaks periodically. Do not use circulators or valves with packing glands, the packing glands can weep.
- **Install a water meter** — Because the system must be installed with automatic water make-up to ensure pressure will always be at least 12 psig, you should install a water meter with one half-gallon resolution on the make-up water line. This will allow monitoring to see if excessive make-up water is entering the system.
- **Circulator sizing** — Glycol/water mixtures do not move heat as well as water only. The circulator size must be increased to account for this. As a rule of thumb, increase the flow rate by 15%. Assume a 10% reduction in pressure drop compared to water only at a give flow rate.
- **Constant circulation** — For areas of the system that will be exposed to low temperatures, use continuous circulation to keep the water moving in the pipes.
- **Expansion tank sizing** — Increase the expansion tank size about 20% to account for the effects of the antifreeze.
- **Indirect heat exchangers** — Output from indirect heat exchangers (including indirect water heaters) can drop substantially when using antifreeze/water. Make sure the exchanger is sized correctly for the application.

**⚠WARNING** Use only antifreeze sold for use in hydronic systems — Never use automotive antifreeze. Automotive antifreeze and ethylene glycol are toxic to humans and animals and will damage rubber components in the system.

Make sure the owner is aware that the antifreeze must be checked periodically by a qualified technician to ensure the concentration is correct and that the inhibitor level is adequate.

Obtain the MSDS for the antifreeze and leave a copy with the owner. Follow antifreeze manufacturer's guidelines for application and maintenance.

Failure to follow these guidelines could result in system or boiler failure, causing possible severe personal injury, death or substantial property damage.

### ❑ System pressure

- Once the system is cleaned, filled, purged and treated as required, set the make-up water pressure reducing valve to the correct cold-fill pressure. This is usually 12 psig for systems using 30 psig relief valves. For higher pressure systems, set the cold-fill pressure such that the system pressure will never exceed about 80% of the boiler relief valve setting when system water temperature reaches the maximum operating temperature that the system and boiler temperature controls will allow.

**⚠WARNING** The pressure in the boiler must never be below 12 psig. Lower pressure could allow localized boiling in the boiler heat exchanger, causing possible damage and section failure.

- At cold fill, the water level in closed-type expansion tanks should not be above center. Use the tank fitting to verify tank water level is correct.
- As the system heats up, the water will expand, causing the system pressure to increase. If the expansion tank is properly sized and installed, the system pressure will never exceed about 80% of the relief valve set pressure (24 psig for typical residential systems).
- If the system operating pressure becomes too high, check the expansion tank to ensure it is large enough. For closed-type expansion tanks, make sure there are no leaks in the piping or the tank and the tank fitting is correctly installed. For diaphragm or bladder-type tanks, you may have to remove the tank from the system and verify that it can hold pressure. If it cannot hold pressure, the membrane may be damaged.

**⚠WARNING** If the system pressure is allowed to rise too high, the boiler relief valve will open, allowing water to escape from the system. The resultant addition of make-up water will cause mineral deposits and oxygen corrosion in the boiler.

### ❑ Final checks

- After the system is cleaned, filled and purged, and the system pressure is correctly set, make sure the water chemistry is correct. The pH and chemistry must be as required (and specified by the chemical treatment specialist when required).
- Make sure all valves are correctly set. Isolation and fill valves should be open before start-up. Purge valves must be closed.
- Open the valve on each automatic vent in the system about one quarter turn to allow venting.
- Thoroughly inspect the system for leaks or weeping valves.

**⚠WARNING** Eliminate all system leaks to prevent excessive make-up water, which introduces oxygen as well as lime-forming minerals. This can lead to heat exchanger damage, resulting in possible severe personal injury, death or substantial property damage.

- Watch the boiler pressure/temperature gauge throughout the start-up process. Make sure the pressure never drops below 12 psig and never goes higher than 80% of the boiler relief valve setting pressure.

# 12

## Starting the boiler

**⚠ WARNING** Failure to adhere to the following could result in severe personal injury, death or substantial property damage.

### Accessibility

The boiler must be accessible from both the right and left sides in order to do a correct start-up/adjustment. Make sure the flame window on the left side and the gas valve throttle adjustment opening in the jacket top are accessible. See Figure 29, page 38.

### Follow the start-up checklist

Perform the start-up check list procedures before starting the boiler.

### Turn off power and fuel supply

Turn off electrical power to boiler if not already off. Close the main manual gas valve at the boiler.

### Verify the gas type

Check the boiler rating plate to make sure that the boiler is for the type of gas that will be used. If it is not, do not the boiler will have to be adjusted for the correct gas, for both high fire and low fire.

### Install boiler per manuals

Read and follow all boiler instructions, including this Boiler manual, the **KN** Vent/air manual and the **KN** Control manual.

All water piping, gas piping, vent piping and air piping must be complete before starting the boiler.

### Check gas piping for leaks

Check all gas piping for leaks, including the boiler interior gas piping and connections, per page 19 of this manual.

### Never leak test with flame

Never use an open flame to test for gas leaks. Always use an approved leak detection method.

### Propane gas applications

The odorant in propane gas can fade over time, reducing or eliminating the gas odor. This makes the gas undetectable by smell. Before start-up, and periodically afterwards, have the propane supplier check/verify the odorant level.

### Never attempt to measure gas valve outlet pressure

Do not attempt to measure the boiler gas valve outlet pressure. The high negative pressure in the venturi can suck fluid out of a manometer, pulling it into the gas valve. This would destroy the gas valve, rendering it unusable.

**⚠ WARNING** Should overheating occur or gas supply fail to shut off:

Do not interrupt water flow to the boiler. Instead, shut off gas supply to the boiler with the manual valve in the gas supply line.

**⚠ AVERTISSEMENT** En cas de surchauffe ou si soupape en gaz ne s'arrête pas :

N'interrompez pas l'écoulement d'eau par la chaudière. Fermez manuellement le robinet d'arrêt de l'admission de gaz.

## Start-up checklist

### Read all boiler manuals

- The **KN** is supplied with three manuals:
  - Boiler manual
  - Vent/air manual
  - Control manual.
- Read and familiarize yourself with all three manuals before proceeding with start-up.

### Check the boiler area

- Make sure there are no combustible materials or chemicals that could cause air contamination in the boiler room.

### Verify vent piping

- Inspect vent piping to be sure all joints are secure and properly sealed.
- Verify vent piping supports are correctly placed and secure.
- Check vent termination to be sure it is correct and not obstructed.
- Measure total vent pipe length and note the number of fittings. Make sure the vent complies with the **KN** Vent/air manual.

### Verify combustion air and ventilation

- If combustion air is supplied from the boiler room, make sure air openings agree with the requirements given in this manual.
- If combustion air is piped to the boiler:
  - Inspect air piping to be sure all joints are secure and properly sealed.
  - Verify air piping supports are correctly placed and secure.
  - Check air inlet termination to be sure it is correct and not obstructed.

# 12

## Starting the boiler *(continued)*

- Measure the air piping length and note the number of fittings. Make sure the air piping complies with the **KN Vent/air** manual.
- Verify ventilation openings to the boiler room. Even if air is piped to the boiler, the boiler room must have ventilation openings as specified in this manual.

### ❑ Verify electrical connections

#### Before turning power on to the boiler:

- Remove the electrical box covers on the right side of the boiler.
- Inspect all wiring and connections. Make sure there are no loose connections or wires.

### ❑ Controls

- Follow the instructions in the **KN Control** manual to set the operating temperatures and parameters required for the installation (if not already done).
- Set limit controls to their lowest settings.
- Verify thermostat circuits following the procedure given in the **KN Control** manual (if not already done).

### ❑ Verify boiler/system water piping

- Inspect all water piping. Make sure it complies with this manual.
- Check the boiler relief valve. Verify the relief valve setting is correct for the application.
- Make sure the boiler and system are full of water and that the system has been purged and is ready for operation.
- System pump — Activate the system pump if it is not controlled by the **KN HeatNet Control**.

### ❑ Verify gas piping and connections

- Before starting the boiler, smell around the area for presence of gas odorant. Immediately locate and correct any leak.
- Connect a manometer to the manual gas valve outlet test port. Open the valve and measure the gas pressure. It must not be above 1/2 psig (3.5 kPa).

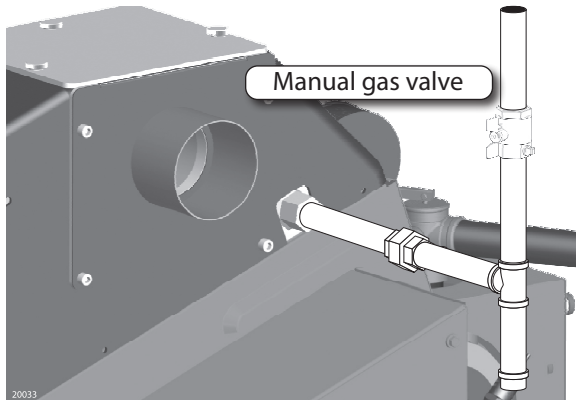

- Open the main manual gas valve and check the gas piping and joints in the boiler. Check for leaks, if not already done, following the instructions on page 19.

### ❑ Prepare the condensate system

- Verify the condensate line is connected to the boiler, correctly installed and terminated.
- Turn on power to the condensate pump (if used).
- Make sure the condensate neutralization system (if used) is functional.
- Slide the condensate hose off of the boiler condensate hose barb. Connect a clear plastic tube (3/16 inch diameter) to the hose barb. Pour water into the tube until water backs into the tube at the hose barb, indicating the trap is full.
- After filling the condensate trap, remove the fill hose.
- Reattach the condensate line to the boiler condensate hose barb.

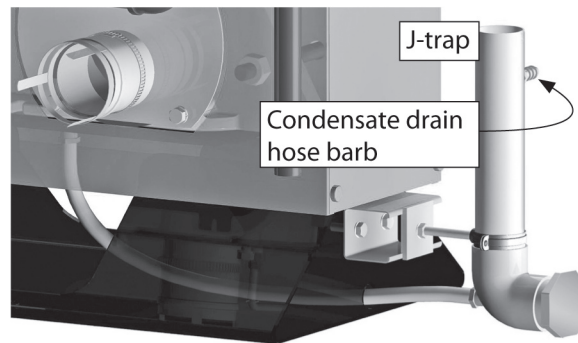

### ❑ Turn on power and gas

- Turn on power to the boiler.
- Open the manual gas valve.

### ❑ Operating instructions

- Adjust system controls or thermostats to call for heat.
- Read about the HeatNet control display on page 34. Then start the boiler following the Operating instructions on page 35 (page 36 for French version).
- The boiler must be checked and adjusted, if necessary, after starting. Once the boiler has started, follow the instructions beginning on page 37 to check boiler operation and adjust as needed, using instruments.

### ❑ If the boiler doesn't start:

- Check external limit controls, low water cut-offs, etc. to be sure they are closed.
- Check the **KN HeatNet** control display for indications of faults.
- Are HeatNet control settings correct for the application?
- Is the gas supply on, and is gas pressure within acceptable range?
- Are room thermostats or building controls calling for heat?
- Are all electrical connections intact?
- If none of the above resolve the problem, follow the troubleshooting guide in the **KN Control** manual.

# 12

## Starting the boiler *(continued)*

**NOTICE** To reset the HeatNet control from lockout: Turn the boiler on/off switch OFF, then back ON.

**Figure 24a** HeatNet control display during operation

The **UPPER LEFT** display shows boiler status. During start sequence, this area will indicate what is happening and then switch to "RUN %\_\_\_". The RUN % is the % of full input.

If there is a call for heat and the supply (or header) temperature is within the Heat band, the display will show "HEATING" until the call for heat stops or the temperature drops low enough for the control to start the boiler.

The **LOWER LEFT** display shows the heat band (temp range from min to max input) and setpoint on the bottom, and the actual temperature along the top. This tells you where the temperature is within the control range.

The image shows a digital display with the text 'RUN % 75' on the left and 'LOC SET' and '160°F' on the right. Below the '160°F' is a horizontal line representing a temperature range, with an upward arrow pointing to the top of the line labeled 'Setpoint' and a downward arrow pointing to the bottom of the line labeled 'Heat band'. A label 'Actual temperature' points to the '160°F' value.

Default readout shows local setpoint or header setpoint; use arrow keys to change to show DHW setpoint, supply temperature, outside temperature, and other values; use the DOWN key to see other values, such as DHW setpoint and supply temp

**Figure 24b** Boiler sequence of operation, fault states and HeatNet control display information

Normal condition	Blower status	Time	Ignition status	Gas valve status	Display (upper left)
Standby (not heat call)	OFF		OFF	OFF	STANDBY
Start (call for heat)	OFF (Flow switch and other interlocks in the flow switch circuit must prove)	10 seconds	OFF	OFF	FLOW WAIT
	OFF if supply temperature is above the bottom of the heat band; circulator runs, but boiler does not fire yet	Demand	OFF	OFF	HEATING
	ON at purge RPM (55% of maximum) when supply temperature drops below the bottom of the heat band	10 seconds			PRE PURGE
Ignition trial	ON at ignition RPM (30% of maximum)	4 seconds	ON	ON	IGN 30%
Flame is sensed (Stabilization period)	ON at ignition RPM (30% of maximum)	6 seconds	OFF	ON	IGN 30%
Operate on demand	ON at RPM based on demand (control determines firing rate % based on demand and rate of change, etc.)	Demand	OFF	ON	RUN %XXX
End call for heat	ON at purge RPM (55% of maximum)		OFF	OFF	POST PRGE
Ignition failure	ON at purge RPM Boiler restarts a normal sequence Control will try 3 times, then lockout	Normal display unless three attempts fail, then shows: IGN LOCKOUT (alternating to) Date & Time of lockout			
Flame failure	ON at purge RPM for postpurge Boiler restarts a normal sequence	Normal display unless ignition is unsuccessful three times after restart			

**NOTICE** For more information: See the KN Control manual for additional information and troubleshooting.



## Starting the boiler *(continued)*

**Figure 25** Operating instructions (for starting boiler only — follow manual instructions to check boiler operation and adjust as needed)

### FOR YOUR SAFETY READ BEFORE OPERATING

**WARNING**

If you do not follow these instructions exactly, a fire or explosion may result, causing property damage, personal injury or loss of life.

- A. This boiler does not have a pilot. It is equipped with an ignition device which automatically lights the burner. **DO NOT TRY TO LIGHT THE BURNER BY HAND.**
- B. BEFORE OPERATING, smell all around the boiler area for gas. Be sure to smell next to the floor because some gas is heavier than air and will settle on the floor. See below.
- C. Use only your hand to turn the gas valve handle. Never use tools. If the handle will not turn by hand, don't try to repair it. Call a qualified service technician. Force or attempted repair may result in a fire or explosion.
- D. Do not use this boiler if any part has been under water. Immediately call a qualified service technician to inspect the boiler and to replace any part of the control system and any gas control that has been under water.

#### WHAT TO DO IF YOU SMELL GAS

- Do not try to light any appliance.
- Do not touch any electric switch; do not use any phone in your building.
- Immediately call your gas supplier from a phone outside of the building. Follow the gas supplier's instructions.
- If you cannot reach your gas supplier, call the fire department.

### OPERATING INSTRUCTIONS

**WARNING**

Do not attempt to operate this boiler unless it has been started, adjusted and maintained at least annually by a qualified heating service technician.

1. STOP! Read the safety information above on this label.
2. Set the thermostat to lowest setting. Turn off all electrical power to the boiler. Press the boiler ON/OFF switch to **OFF**.
3. **DO NOT TRY TO LIGHT THE BURNER BY HAND.**
4. Turn manual gas valve handle clockwise ↻ to **CLOSE** the gas valve. (Gas valve may have lever handle. Valve location will vary by installations.)
5. Wait five (5) minutes to clear out any gas. Then smell for gas, including near the floor. If you smell gas, **STOP!** Follow "B" in the safety information above. If you don't smell gas, go to the next step.
6. Turn manual gas valve handle counterclockwise ↻ to **OPEN** the gas valve.
7. Turn ON all electrical power to the boiler.
8. Set the thermostat to its highest setting. Press the ON/OFF switch to **ON**.
9. The DISPLAY will cycle through the ignition sequence, and show "RUN" when the boiler is operating.
10. If the boiler does not operate, follow the instructions below to "TURN OFF GAS TO BOILER." Call your service technician or gas supplier.

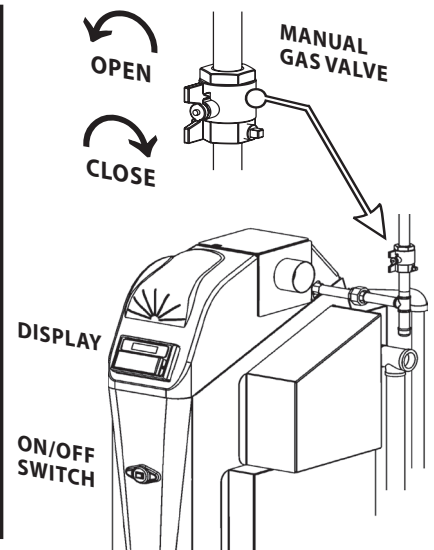

### TO TURN OFF GAS TO BOILER

1. Set the thermostat to its lowest setting.
2. Turn off all electric power to the boiler if service is to be performed.
3. Turn manual gas valve handle clockwise ↻ to **CLOSE**. DO NOT FORCE THE HANDLE.

## Starting the boiler (continued)

Illustration 26 En française . . .

### POUR VOTRE SÉCURITÉ LISEZ ANANT DE METTRE EN MARCHÉ

#### AVERTISSEMENT

Quiconque ne respecte pas à la lettre les instructions dans la présente notice risque de déclencher un incendie ou une explosion entraînant de dommages, des blessures ou la mort.

- A. Cet appareil ne comporte pas de veilleuse. Il est muni d'un dispositif d'allumage qui allume automatiquement le brûleur. **Ne tentez pas d'allumer le brûleur manuellement.**
- B. AVANT DE FAIRE FONCTIONNER, reniflez tout autour de l'appareil pour déceler une odeur de gaz. Reniflez près du plancher, car certains gaz sont plus lourds que l'air et peuvent s'accumuler au niveau du sol. Voir ci-dessous.
- C. Ne poussez ou tournez la manette d'admission du gaz qu'à la main ; ne jamais utiliser d'outil. Si la manette reste coincée, ne pas tenter de la réparer ; appelez un technicien qualifié. Le fait de forcer la manette ou de la réparer peut déclencher une explosion ou un incendie.
- D. N'utilisez pas cet appareil s'il a été plongé dans l'eau, même partiellement. Faites inspecter l'appareil par un technicien qualifié et remplacez toute partie du système de contrôle et toute commande qui ont été plongés dans l'eau.

#### QUE FAIRE SI VOUS SENTEZ UNE ODEUR DE GAZ

- Ne pas tenter d'allumer d'appareil.
- Ne touchez à aucun interrupteur ; ne pas vous servir des téléphones se trouvant dans le bâtiment.
- Appelez immédiatement votre fournisseur de gaz depuis un voisin. Suivez les instructions du fournisseur.
- Si vous ne pouvez rejoindre le fournisseur, appelez le service des incendies.

### INSTRUCTIONS DE MISE EN MARCHÉ

#### AVERTISSEMENT

N'essayez pas de faire fonctionner cette chaudière à moins qu'elle ait été démarrée, ajustée et entretenue au moins annuellement par un technicien d'entretien de chauffage qualifié.

1. ARRÊTEZ! Lisez les informations de sécurité ci-dessus sur cette étiquette.
2. Réglez le thermostat au niveau le plus bas. Coupez tout courant électrique à la chaudière. Appuyez sur le commutateur ON/OFF (MARCHÉ/ARRÊT) de la chaudière pour le mettre à OFF (ARRÊT).
3. **NE TENTEZ PAS D'ALLUMER LE BRÛLEUR MANUELLEMENT.**
4. Tournez la manette de soupape à gaz dans le sens des aiguilles d'une montre pour FERMER la soupape à gaz. (La soupape à gaz peut avoir un levier. L'emplacement de la soupape variera d'une installation à l'autre.)
5. Attendez cinq (5) minutes pour que tout gaz se dissipe. Sentez alors pour détecter la présence de gaz, y compris près du plancher. Si vous sentez du gaz, ARRÊTEZ! Suivez « B » dans les informations de sécurité ci-dessus. Si vous ne sentez pas de gaz, passez à la prochaine étape.
6. Tournez la manette de soupape à gaz dans le sens contraire des aiguilles d'une montre pour OUVRIER la soupape à gaz.
7. Allumez tout courant électrique à la chaudière.
8. Réglez le thermostat à son niveau le plus élevé. Appuyez sur le commutateur ON/OFF (MARCHÉ/ARRÊT) pour le mettre à ON (MARCHÉ).
9. L'AFFICHEUR fera une manœuvre de séquence d'allumage et affichera « RUN » (EN FONCTION) lorsque la chaudière fonctionnera.
10. Si la chaudière ne fonctionne pas, suivez les instructions ci-dessous pour « ARRÊTER LE FLUX DE GAZ VERS LA CHAUDIÈRE ». Appelez votre technicien d'entretien ou votre fournisseur de gaz.

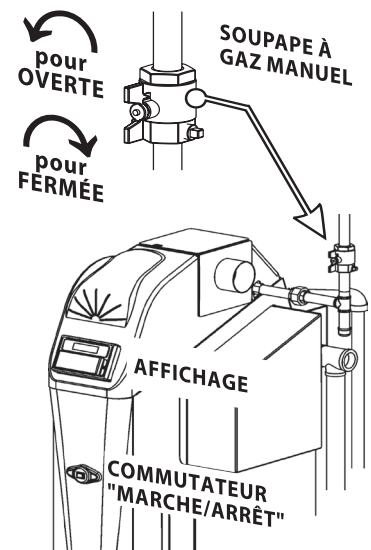

### COMMENT COUPER L'ADMISSION DE GAZ DE L'APPAREIL

1. Réglez le thermostat à la température la plus basse.
2. Coupez l'alimentation électrique de l'appareil s'il faut procéder à l'entretien.
3. Tournez la manette de soupape à gaz dans le sens des aiguilles d'une montre pour la FERMER. **NÉ FORCEZ PAS LA MANETTE.**

## Starting the boiler *(continued)*

### Turn the boiler OFF

1. Turn **OFF** the boiler on/off switch and allow the boiler to cycle off.
2. **CLOSE** the manual gas valve.
3. Multiple boiler HeatNet applications — Disconnect the communications cable or 3-wire connection to the boiler connection board. (Replace when done.)

### Check ignition

1. With the manual gas valve **CLOSED**, start the boiler with the on/off switch.
2. Look into the flame window, left side of the boiler (Figure 29, page 38).
3. When ignition starts, the spark should jump between the electrodes, not to other surfaces.
4. The spark should be strong and steady. If the spark is acceptable, turn the boiler on/off switch **OFF**. Then proceed with the start-up adjustment procedure.
5. If the spark jumps to ground or is unsteady, turn the boiler **OFF**. See the Maintenance section of this manual for the procedure to remove and inspect the electrode assembly. Replace the electrode assembly if it is damaged or not within specifications.

### Insert combustion analyzer probe

**⚠ WARNING** The boiler must be checked and adjusted using combustion test instruments. Failure to accurately measure flue gas analysis and adjust the boiler as needed could result in severe personal injury, death or substantial property damage.

1. After the boiler has cycled off, loosen the hose clamp covering the flue gas sampling hole (Figure 27).

**⚠ CAUTION** The flue gas vent pipe may be hot. Touching the pipe with unprotected skin could result in a severe burns.

2. Slide the hose clamp off of the sample opening.
3. Insert the combustion analyzer probe into the sample opening.
4. If using an electronic analyzer, zero and calibrate it before proceeding.
5. If using a chemical analyzer, make sure that the fluid is fresh and is at room temperature. Have a monoxer and test tubes available to test carbon monoxide levels.

### Check high fire operation

1. Remove the electrical panel cover on the right side of the boiler (see item 11, page 3) as in Figure 28.

**⚠ WARNING** **Electrical shock hazard** — The electrical box contains line-voltage wiring and contacts. Use caution when working in the electrical box to avoid contact with line-voltage elements. Turn off power to the boiler panel if necessary.

2. Connect a jumper wire across the high-fire terminals of the connector board (Figure 28). These terminals are located on the lower row as shown.
3. Turn the boiler on/off switch **ON**.
4. The boiler will start at about 30% of maximum input and immediately go to high fire.
5. Observe the flame through the flame window (left side of boiler; see Figure 29).
  - The flame should be blue and well-defined, with white traces.
  - If the flame is too lean (too much air), it will be light blue and unsteady.
  - If the flame appears reddish, or there are red areas on the burner surface, turn the boiler **OFF** and reduce fuel with the gas valve throttle (see page 38).
6. Check the analyzer. A rapid increase in CO is an indicator of bad combustion. Turn the boiler **OFF** and reduce fuel input as explained on page 38.

**Figure 27** Flue gas sampling hole

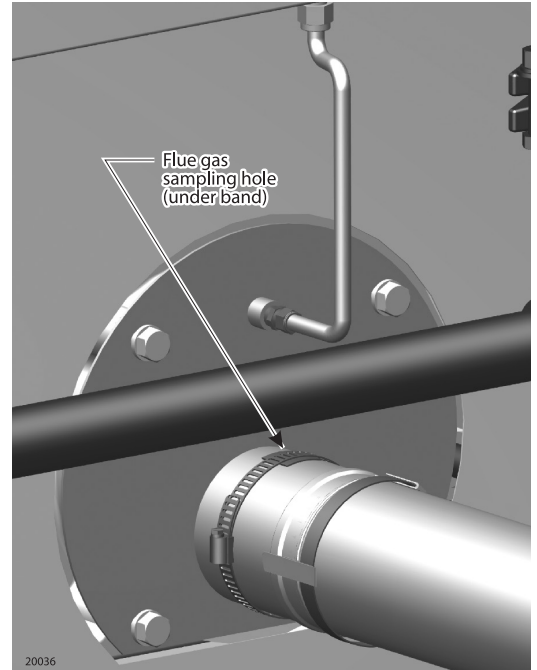

**⚠ AVERTISSEMENT** Seal sampling hole with high temperature silicone after each combustion test and annual inspection to prevent gases and condensation from leaking during appliance operation.

**Figure 28** Electrical panel

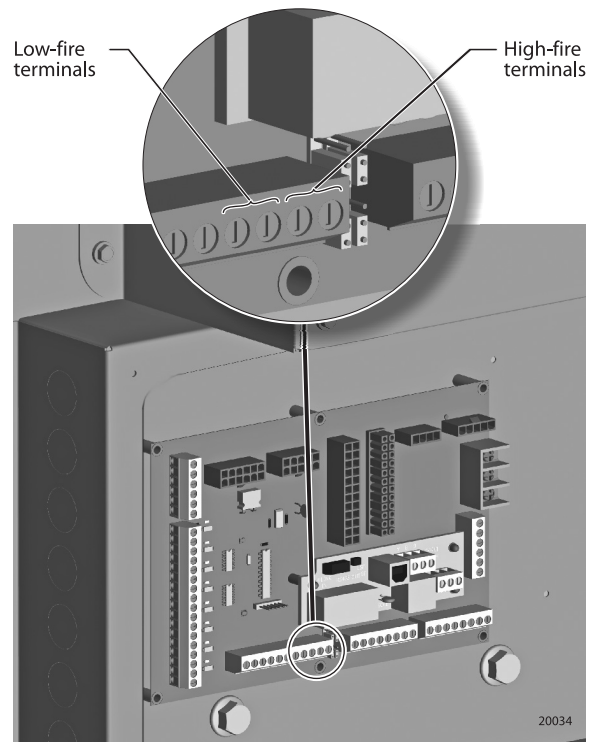

## Starting the boiler *(continued)*

### Adjust gas valve throttle setting

#### Allow combustion to stabilize

- Allow the boiler to operate 15 minutes, or as needed to obtain a steady reading on the analyzer.

**⚠ WARNING** If the flame or burner surface appear red, **NO NOT** allow the boiler to run without adjusting the gas valve throttle to reduce fuel input as described below. Proceed with final throttle setting only if the flame is visually acceptable (blue and steady).

#### Acceptable CO<sub>2</sub>/O<sub>2</sub> values

- The CO<sub>2</sub>/O<sub>2</sub> values must be within the limits given in Table 5. The flame must be blue and steady as discussed on page 37. CO must be no higher than 50 ppm.

**Table 5** Acceptable CO<sub>2</sub> and O<sub>2</sub> values

<b>Natural gas – High fire</b>	<b>CO<sub>2</sub> / O<sub>2</sub></b>	<b>Natural gas – Low fire</b>	<b>CO<sub>2</sub> / O<sub>2</sub></b>
Minimum %	8.4 / 6.2	Minimum %	7.5 / 7.8
Maximum %	9.5 / 4.2	Maximum %	8.2 / 6.5
<b>Propane – High fire</b>	<b>CO<sub>2</sub> / O<sub>2</sub></b>	<b>Propane – Low fire</b>	<b>CO<sub>2</sub> / O<sub>2</sub></b>
Minimum %	9.3 / 6.2	Minimum %	8.2 / 7.8
Maximum %	10.7 / 4.2	Maximum %	9.1 / 6.5

#### Adjusting gas input with throttle screw - max input

- Adjust gas input with the throttle screw adjustment using a long-shank common bit screwdriver inserted through the hole in the jacket top. (Figure 29)
- When adjusting the throttle setting, make changes in half-turn increments. Allow the flame to stabilize before adjusting each time. (Reduce gas input if the flame or burner appears red.)
- If CO<sub>2</sub> is too **HIGH** (O<sub>2</sub> too low):
  - REDUCE** gas by turning the adjustment **CLOCKWISE** (one half turn at a time). Recheck the analyzer and flame after each half turn.
- If CO<sub>2</sub> is too **LOW** (O<sub>2</sub> too high):
  - INCREASE** gas by turning the adjustment **COUNTERCLOCKWISE** (one half turn at a time). Recheck the analyzer and flame after each half turn.

#### Verify gas inlet pressure

- With the boiler operating at high fire, check the gas pressure at the manual gas valve. Gas pressure should never fall off by more than 2 inches WC (50 mm).

#### To meter gas input (natural gas only):

- Meter gas input with the high-fire jumper in place.
- Turn off all other gas appliances that use the same gas meter as the boiler.
- Call your gas supplier and ask for the heating value of the gas (Btu per cubic foot).
- Start the boiler and let it run for 15 minutes (high-fire jumper in place).
- With the boiler operating, clock the time in **SECONDS** that it takes to burn **10** cubic feet of gas at high fire.
- Insert the heating value and the time, in seconds, into the formula below.
 
$$\text{Input} = [\text{Gas Btu per cubic foot}] \times [3600] \times [10] \div [\text{seconds}]$$
- If the computed rate exceeds the desired input rate or 200,000 Btuh, reduce the gas input with the gas throttle adjustment.

**Figure 29** Throttle adjustment and flame window

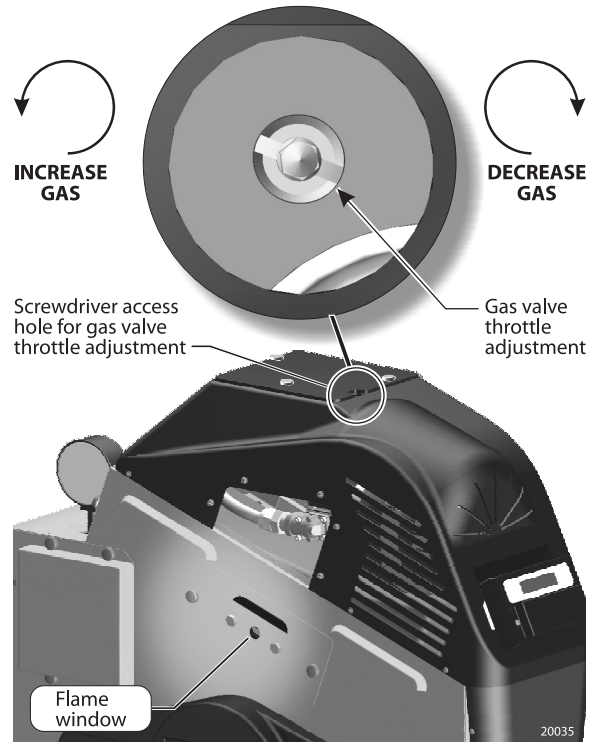

**⚠ WARNING** Never operate the boiler at an input higher than its rating. Excess input can result in overheating and damage to the heat exchanger and boiler components.

#### Check low fire operation.

- Turn the boiler on/off switch **OFF**.
- Remove the high-fire contact jumper. Connect the jumper wire across the low-fire terminals of the connector board (Figure 28, page 37). These terminals are located on the lower row as shown.
- Turn the boiler on/off switch **ON**.
- The boiler will start at about 30% of input and then move to the low fire condition.
- Make sure the flame is blue and steady, **NOT** red or light blue and unsteady.
- If the flame or burner appears red, or if the CO<sub>2</sub> or O<sub>2</sub> are outside the ranges of Table 5, turn the boiler on/off switch **OFF**.
- See the next page for instructions to adjust the gas valve low-fire setting.
- If flame and CO<sub>2</sub>/O<sub>2</sub>/CO are acceptable, proceed with set-up (page 40) — **No further gas valve adjustments are needed**. Replace the gas valve cover plate. Remove the low-fire jumper and replace the electrical panel cover.

**⚠ WARNING** **Changing from propane to natural gas or natural gas to propane** — When adjusting the boiler for a different gas, the low-fire gas adjustment must be changed using the procedure on page 39.



## Starting the boiler *(continued)*

### When is low fire adjustment required?

**NOTICE** Adjust the gas valve low-fire setting **ONLY** if the flame is unacceptable, the CO<sub>2</sub>, O<sub>2</sub> or CO are out of acceptable range or you are changing fuels. You will need to remove the boiler jacket top and adjust the gas valve low-fire setting as described below.

**The boiler jacket top must be removed** when it is necessary to access the gas valve low-fire adjustment screw or other interior components, such as the blower motor. Use the procedure below.

### Removing the boiler jacket top

1. See Figure 30.
2. Remove the three thumb screws securing the filter access plate.
3. Remove and set aside the filter access cover and gasket.
4. Pull back on the filter clamp and remove the filter.
5. Hold the filter clamp back as in Figure 30.
6. Squeeze the conical grommet sides and maneuver the grommet out of the opening in the jacket top.
7. If there is no air pipe attached to the air inlet, leave the air inlet plate in place.
8. If air is piped to the air inlet plate, remove the air inlet plate and gasket by removing the four screws that secure it to the jacket top. Make sure the air piping is properly supported.
9. Remove the seven Phillips-head screws securing the jacket top to the jacket sides.
10. Lift off the jacket top. (Leave the wire harnesses connected.)
11. Move the insulation aside if necessary.

### Adjusting the low-fire setting

**NOTICE** **DO NOT** adjust the low-fire setting unless low-fire flame or combustion are unacceptable.

1. See Figure 31 for the location of the gas valve low-fire adjustment. Use a 2-mm hex wrench.
2. When adjusting the low-fire setting, make changes in half-turn increments. Allow the flame to stabilize before adjusting each time. (Reduce gas input if the flame or burner appears red.)
3. If CO<sub>2</sub> is too **HIGH** (O<sub>2</sub> too low):
  - **REDUCE** gas by turning the adjustment **COUNTERCLOCKWISE** (one half turn at a time). Recheck the analyzer and flame after each half turn.
4. If CO<sub>2</sub> is too **LOW** (O<sub>2</sub> too high):
  - **INCREASE** gas by turning the adjustment **CLOCKWISE** (one half turn at a time). Recheck the analyzer and flame after each half turn.

### Replace the boiler jacket top

1. To replace the jacket top, reverse this order above. Make sure insulation is in place.
2. Slide the conical grommet over the blower inlet. Then seat the grommet ring into the hole in the jacket top.
3. Reattach the air inlet plate if it was removed. Inspect the air piping to make sure it was not displaced.
4. Pull the air filter clamp back. Replace the filter, gasket and access cover. Secure with the three thumbscrews. Replace the gas valve cover plate if removed.
5. Remove the low-fire jumper from the connection board. Replace the electrical panel cover.

**Figure 30** Removing boiler jacket top

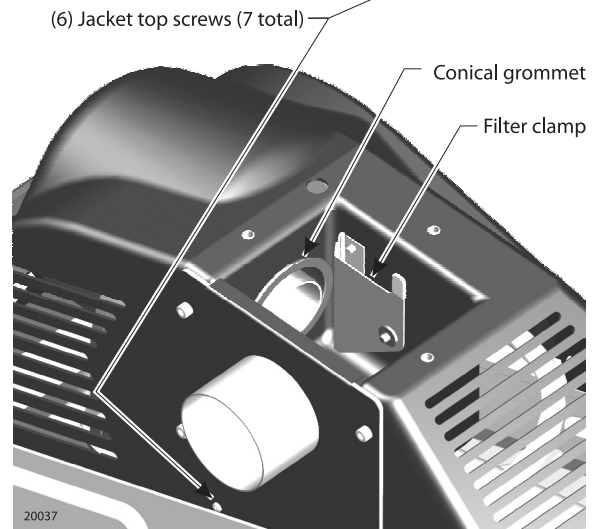
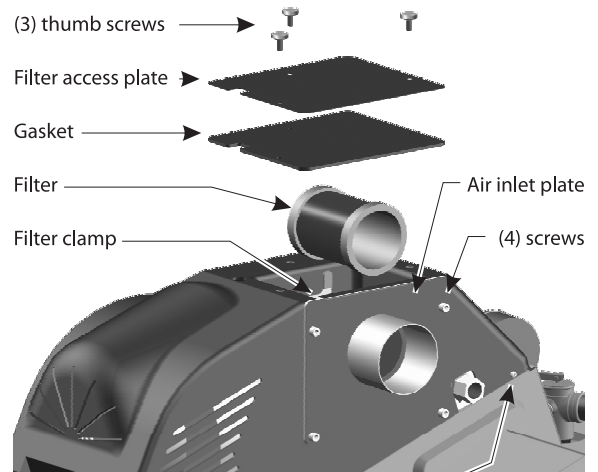

**Figure 31** Gas valve adjustments

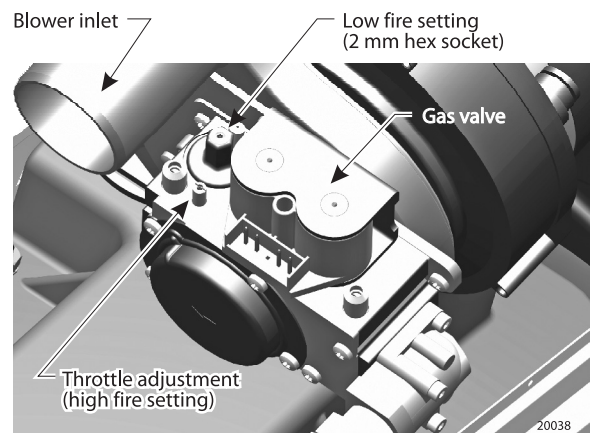



## Starting the boiler *(continued)*

### Measure flame current

**⚠ WARNING Electrical shock hazard** — The electrical box contains line-voltage wiring and contacts. Use caution when working in the electrical box to avoid contact with line-voltage elements. Power must be on to measure flame current.

1. With the boiler operating at **low fire** (low-fire jumper in place), measure the flame current.
2. Remove the upper electrical panel cover (upper right side of boiler).
3. Attach microammeter leads to the flame current test pins of the Fenwal ignition module as in Figure 32.
4. The flame current should be approximately 6 microamps, and never less than 1 microamp. Record the flame current value on the back page of this manual.
5. If flame current is acceptable, continue with setup. If flame current is too low, check the ignition electrode/flame rod assembly following the instructions in the Maintenance section of this manual.

### Check boiler modulation

1. Remove the low-fire jumper from the electrical connection panel (see Figure 28).
2. The boiler firing rate should change to meet demand. The HeatNet control display will show the percentage of maximum firing rate (between 20% and 100%).

### Test flame failure modes

#### Flame loss

1. With the boiler running in normal operation, close the manual gas valve on the incoming gas line.
2. Within 0.8 second after the flame goes out, the boiler gas valve should shut off.
3. The HeatNet control will restart operation with prepurge, then continue through a normal start cycle.
4. With the manual gas valve closed, the boiler should attempt ignition three times, then lockout, as described below.

#### Ignition failure

1. Make sure there is a call for heat.
2. Turn the boiler on/off switch **OFF**.
3. Close the manual gas valve on the gas supply line.
4. Turn the boiler on/off switch **ON**.
5. The boiler should start a regular cycle.
6. When the boiler attempts ignition, no flame will occur. Within 4 seconds of ignition start, the control will close the boiler gas valve and attempt another start.
7. After three failed ignition attempts, the Fenwal control will lockout.
8. The boiler will shut off and the HeatNet control display will show "LOCKOUT."
9. Open the manual gas valve.
10. Reset the controls by turning the boiler on/off switch off, then on again.
11. The boiler should restart and operate normally.

### Test control & interlock operation

#### Test HeatNet operating limit function

1. Allow the boiler to fire until the supply temperature reaches the upper end of the control band.

**Figure 32** Throttle adjustment and flame window

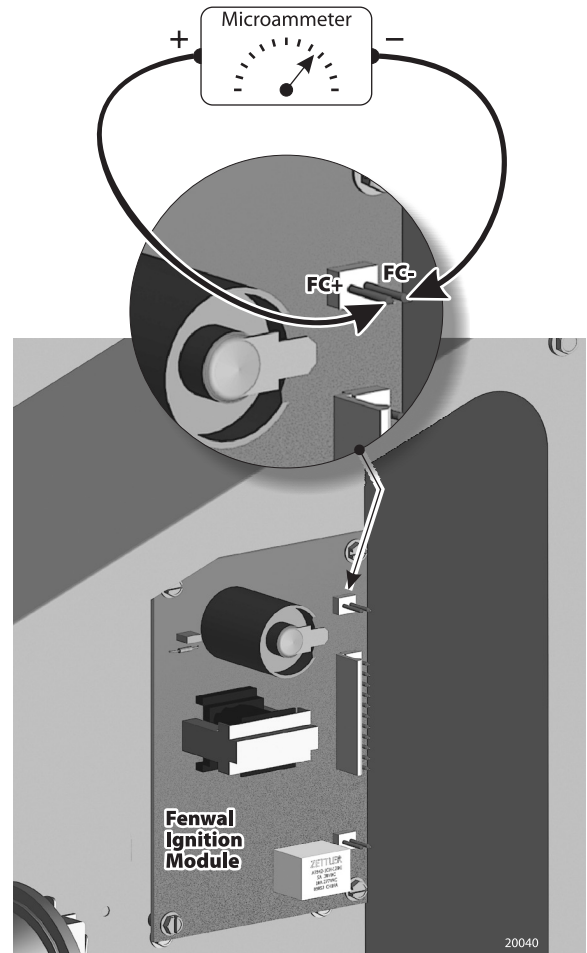

2. The boiler should gradually cycle to minimum input (firing rate = 20%), then turn off.

#### Test external controls

1. Lower the setting of external limit controls below the supply water temperature. Verify that the controls shut down as required.
2. Test operation of low water cut-offs, flow switches and other external devices.
3. Test external gas pressure interlocks, if used.
4. Test/verify operation of combustion air dampers and end switches, if used.

#### DHW applications

1. For DHW applications, verify that the boiler operates on demand from the indirect water heater and shuts off as required.

### Fill out the installation certificate

1. Complete the checklist and installation certificate on the back page of this manual.

## Annual start-up

**⚠WARNING** The boiler and system must be inspected, started and serviced at least annually by a qualified service technician. Follow all procedures specified in the **KN** manuals. Failure to inspect, test and maintain the boiler and system could result in severe personal injury, death or substantial property damage.

**⚠WARNING** **Electrical shock hazard** — Use caution when working on the boiler where electrical components are exposed. Turn off power to the boiler if necessary to avoid potential for electrical shock.

### Annual start-up overview

#### Perform start-up, pages 32 – 40

Perform the complete start-up, testing and inspection procedures given on pages 32 through 40 to ensure the boiler and system comply with the requirements in this manual.

In addition, perform the additional follow-up procedures given below.

#### Perform follow-up procedures

Operating conditions or abuse can damage the boiler or system components. The start-up checklist that follows includes inspections and testing intended to verify that the boiler and system are still fully functional.

### Annual start-up checklist

#### Discuss system performance with the homeowner or boiler operator

- Ask the homeowner or boiler operator to rate the performance of the heating system over the last season.
- If the homeowner or boiler operator identifies boiler or system problems, identify the cause and adjust or repair as necessary.

#### Inspect the air filter

- Remove, inspect (and clean if needed) the air filter. (See instructions in the Maintenance section.)

**⚠WARNING** If the filter enclosure and blower inlet show signs of drywall dust, construction debris or other deposits, you may need to inspect the burner. Follow the procedure in the Maintenance section. Accumulation of debris in the burner can result in burner damage and potential for severe personal injury, death or substantial property damage.

**⚠WARNING** If the burner is removed for inspection, also inspect the boiler heat exchanger. If the heat exchanger is damaged or blocked with debris, consult the factory for corrective action. Operating the boiler with a damaged or

obstructed heat exchanger could result in severe personal injury, death or substantial property damage.

#### Verify boiler water treatment

- If the system requires water treatment, make sure the treatment is being performed as required. Ensure that the water softener, if used, is operational and is being maintained.
- If the system uses antifreeze, check the antifreeze concentration and inhibitor level. If the levels are low, check for leaks or other causes. Adjust the antifreeze level or refill the system as indicated.

#### Check expansion tank & air vents

- Inspect the relief valve and piping to be sure there are no signs of relief valve leakage.
- If the relief valve has been weeping, make sure the expansion tank is not waterlogged or undersized.
- When performing the boiler start-up, watch the pressure gauge as the boiler and system heat up. If the pressure rises too fast or too high, the relief valve is not working properly. Correct the problem as required.
- Make sure all air vents are operating correctly.

#### Inspect and test the relief valve

- Follow the instructions on the relief valve label to inspect and test the boiler relief valve.

**⚠WARNING** When discharging the relief valve, make sure there is not risk of spraying water to you or others.

#### Condensate line maintenance

- Make sure the condensate line, condensate pump and neutralization system, if used, are operational.
- Remove the condensate line at the boiler hose barb connection.
- Pour water into the line and make sure the water drains freely. Flush or replace the line if necessary.
- Fill the condensate trap by attaching a 3/8 inch clear plastic tube to the hose barb. Pour water into the tubing until the trap is full.
- Remove the clear tubing and reattach the condensate line to the boiler hose barb.

#### Perform a complete start-up

- Inspect, adjust and start-up the boiler and system components as instructed on pages 32 through 40. Perform all procedures to ensure the boiler and system are operating properly.

#### Review with homeowner/operator

- Review the User's information manual with the homeowner or operator.
- Make sure that all maintenance procedures are being followed and that all instructions are clear and understood.

## Maintenance

### Read before proceeding

**⚠️ WARNING** Failure to adhere to the following could result in severe personal injury, death or substantial property damage.

#### Licensed technician only

The procedures in this manual must only be done by a qualified service technician. Some details of service procedures are left to the expected good practices of a qualified technician.

#### Electrical shock hazard

Except when the boiler must be tested or adjusted with the power on, always turn power **OFF** before servicing the boiler.

#### Burn or scald risk

Always allow the boiler and parts to cool before attempting to service or remove. Some parts may be very hot.

Do not open water piping components unless the water has been allowed to cool to avoid scald hazard from spraying hot water.

#### Test/verify the boiler after servicing

Following service of any kind, verify that the boiler, controls and system devices are fully functional by performing the appropriate start-up testing procedures given in this manual.

#### Seals

If any pressure-tight seal is broken for servicing (such as combustion chamber/burner seals, air or vent piping joints or seals, or gas piping joints or seals, make sure the seal is restored when servicing is complete. Gaskets must be in good position and placed as originally installed.

#### Read the instructions

Do not attempt the procedures in this manual without thoroughly reading the instructions given. Follow all instructions.

#### If problems can't be resolved

If following the procedures in the **KN** manuals do not resolve problems, contact Advanced Thermal Hydronics for technical support to resolve the issues.

### Handling ceramic fiber and fiberglass materials

**⚠️ WARNING** The **KN** boiler contains some ceramic fiber and fiberglass materials. Ceramic fiber materials, such as the burner gasket, may contain carcinogenic particles (chrysothalites) after exposure to heat. Airborne particles from fiberglass or ceramic fiber components have been listed as potentially carcinogenic by the State of California. Take the following precautions when removing, replacing and handling these items.

#### Protective measures

- Avoid breathing dust and avoid contact with skin or eyes. Wear long-sleeved, loose-fitting clothing, gloves and eye protection. Use a NIOSH N95 certified respirator. This respirator meets requirements for protection from chrysothalites. The actual job requirements or NIOSH regulations may require other or additional protection. For information, refer to the NIOSH website, <http://www.cdc.gov/niosh/homepage.html>.

#### Ceramic fiber removal

- Ceramic fiber removal: To prevent airborne dust, thoroughly wet ceramic fiber with water before handling. Place ceramic fiber materials in a plastic bag and seal to dispose.
- Avoid blowing, tearing, sawing or spraying fiberglass or ceramic fiber materials. If such operations are necessary, wear extra protection to prevent breathing dust.
- Wash work clothes separately from other laundry. Rinse clothes washer thoroughly afterwards to prevent contamination of other clothing.

#### NIOSH First aid procedures:

- Eye exposure — irrigate immediately
- Breathing — fresh air.

## Maintenance *(continued)*

### Cleaning the air filter

1. Turn the boiler on/off switch **OFF**.
2. Remove the three thumb screws that secure the filter access plate (see Figure 33).
3. Remove the filter access plate and gasket.
4. Pull the filter clamp back and remove the air filter.
5. Inspect the filter and the filter enclosure area for dust or debris.
6. Clean the filter, if necessary, by washing under running water. Shake off excess water and towel dry.

**⚠WARNING** If the filter enclosure and blower inlet show signs of drywall dust, construction debris or other deposits, you may need to inspect the burner. Follow the procedure in this section. Accumulation of debris in the burner can result in burner damage and potential for severe personal injury, death or substantial property damage.

7. If the filter is damaged or cannot be cleaned effectively, obtain a replacement filter from your boiler distributor.
8. To replace the air filter, pull the filter clamp back, insert the filter, and allow the clamp to secure the filter in place.
9. Replace the filter access cover gasket and access cover.
10. Replace the three thumbscrews and finger tighten securely.
11. Turn the boiler on/off switch **ON**.

### Accessing the electrode assembly

1. Turn the boiler on/off switch **OFF**.
2. If the boiler ignition electrodes or flame rod appear to be operating incorrectly, remove and inspect the assembly as follows.

**⚠WARNING** Do not remove the electrode assembly while the boiler is operating. Allow the boiler and electrode assembly to cool before attempting removal to avoid possible burns. Failure to comply could result in severe personal injury.

3. With the boiler and manual gas valve closed, remove the upper electrical box cover (right side of boiler).
  - Remove the two 1/4 inch bolts that secure the electrode/flame rod assembly to the boiler (Figure 34).
  - The electrode spacing *and* insertion depth must be as shown in Figure 34.
4. If the electrodes or flame rod are damaged or the tip spacing is incorrect, replace the assembly.
5. Re-install the assembly in the boiler.

**⚠WARNING** Make sure the electrode plate gasket is in good condition and that the assembly is securely bolted to the boiler. The combustion chamber operates with a positive pressure. Failure to comply could result in severe personal injury, death or substantial property damage.

**Figure 33** Accessing the air filter

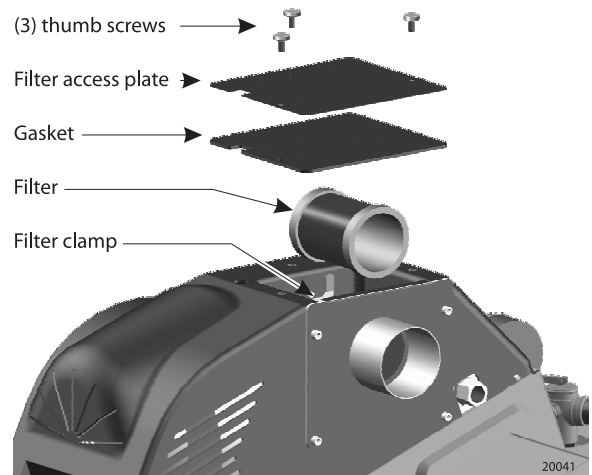

**Figure 34** Electrode/flame rod assembly inspection

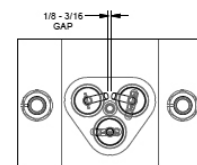
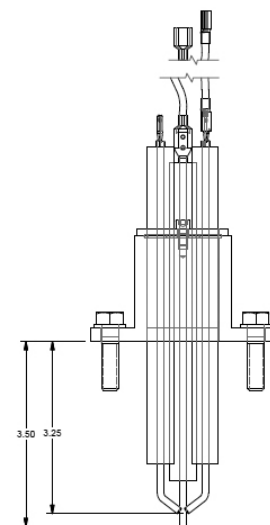
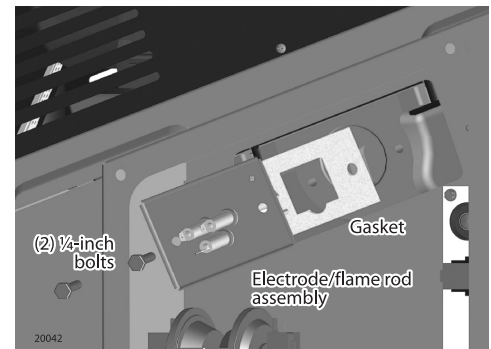



## Maintenance *(continued)*

### Accessing the burner

**⚠ WARNING** If the filter enclosure and blower inlet show signs of drywall dust, construction debris or other deposits, you may need to inspect the burner. Follow the procedure below. Accumulation of debris in the burner can result in burner damage and potential for severe personal injury, death or substantial property damage.

**NOTICE** Perform this procedure only if evidence indicates the burner may be fouled or damaged.

1. Turn the boiler on/off switch **OFF**.
2. Close the manual gas valve.
3. Remove the boiler jacket top following the procedure given on page 39.
4. Disconnect the gas supply piping at the ground joint union installed adjacent to the boiler.
5. Carefully remove the upper insulation (item 4, Figure 35) that covers the upper section cover. See Figure 35. Set the insulation aside for reuse.

**⚠ WARNING** The upper insulation must be replaced after completing this work to prevent overheating of the gas valve, blower and jacket top.

6. To access the bolts and nuts that secure the upper section cover:
  - Remove the sheet metal cover plate at the flame observation window (item 1, Figure 35).
  - Remove the plastic plug from the jacket rear (item 2, Figure 35).
  - Remove the upper electrical panel cover plate (item 3, Figure 35).
  - Removing these items provides open-end wrench access to the 1/4 inch bolts and nuts.
7. Remove the seven 1/4 inch bolts, nuts and washers that secure the upper section cover (item 2, Figure 36). Note for reinstallation that there is a flat washer on both sides of the assembly and a lock washer on top.
8. Disconnect the three wire harnesses at the gas valve and blower (items 2 and 3, Figure 36). In this illustration, the wires are not shown.
9. Lift the upper cover plate/blower/gas valve assembly off of the section assembly. (The upper section cover gasket is adhered to the bottom of the cover with silicone RTV.)
10. The burner is now exposed.
11. Lift the burner up as in Figure 37 and inspect both sides. (The burner gasket is adhered to the bottom of the cover with silicone RTV.)
12. Look down into the section assembly to verify it is clean. If the heat exchanger is blocked with sediment or shows damage, contact Advanced Thermal Hydraulics immediately for corrective action.
13. If the burner is damaged, obtain a replacement burner from your distributor. Install the new burner.
14. If the burner is fouled with debris, attempt to clean by using a shop vacuum. Be careful not to damage the burner surface. If the burner cannot be cleaned, obtain a replacement from your distributor.
15. Inspect the ceramic fiber chamber (item 3, Figure 37) and fiber gasket (item 2, Figure 37). Make sure they are in good condition, or replace.
16. Replace the burner or install a new one.
17. Replace all components in the reverse order from above.

**⚠ WARNING** Use extreme care when replacing the upper section cover. The seal must be secure to avoid potential of carbon monoxide leakage or heat damage caused by flue gas spillage. Inspect all components to ensure they are in good condition and correctly installed. Soap suds leak test the gas line, particularly the ground joint union, to ensure the gas line is intact after servicing. Follow servicing by a complete start-up/test procedure of the boiler.

**Figure 35** Preparing to remove upper section cover

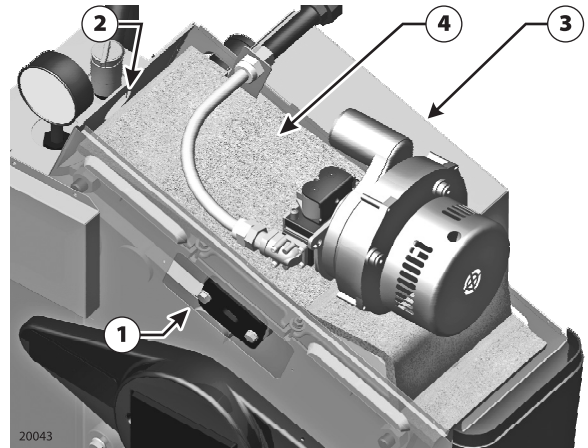

**Figure 36** Upper cover bolt locations

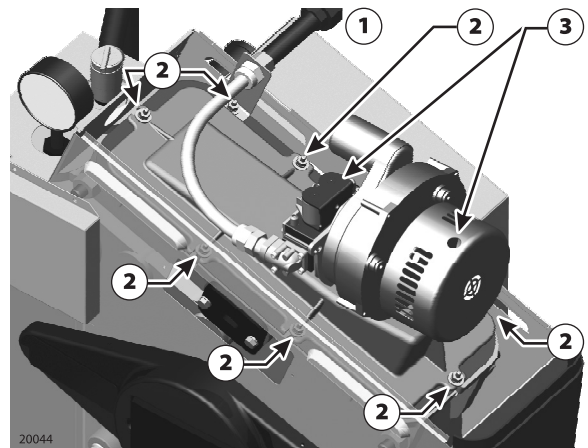

**Figure 37** Burner and chamber

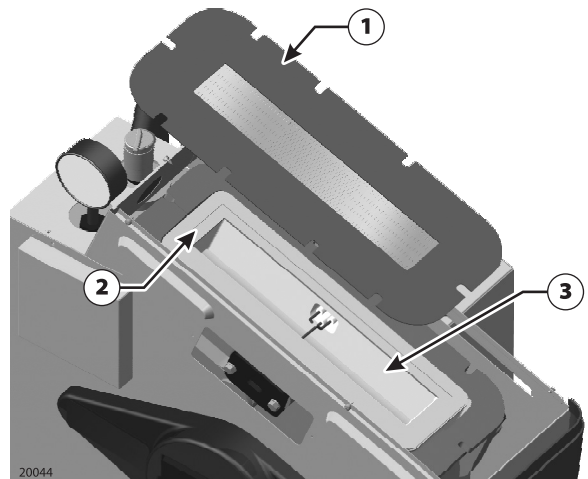





## KN-2 Replacement parts

ITEM	PART No.	DESCRIPTION	QTY
1	20-1022	T&P Gauge	1
2	70-1552	Jacket Panel Assembly	1
5	58-1555	Illuminated Rocker Switch	1
NS	01-1629	Front Section	1
NS	01-1627-1	Rear Section	1
11	70-1421	Blank Box Assembly	1
17	60-4280	Sight Glass	1
19	57-3657	Filter Box Thumb Screw	3
22	59-1089	Combustion Air Filter	1
24	59-1091	Filter Box Adapter Gasket	1
29	02-1580	Gas Valve	1
31	70-1657	Burner Assembly	1
	70-6674	Burner (Only)	1
NS	59-1086	Lower Chamber Gasket	1
33	22-1203	30 psi Relief Valve	1
	22-1200	50 psi Relief Valve	1
	22-1803	75 psi Relief Valve	1
	22-1201	100 psi Relief Valve	1
35	70-6700	Ignitor Assembly	1
	04-1344	Spark Rod	1
	04-1345	Ground Rod	1
	04-1346	Flame Sensor	1
	59-2035	O'ring	3
36	02-4296	Ignition Control	1
	59-1112	Ignition Block Gasket	1
37	03-1756	Ignition Cover	1
38	02-3928	High Limit Switch	1
39	02-3927	Operator - Supply Sensor	1
40	03-1776	Ignition Box Cover	1
41	09-1520	TACO 005 W/Internal Flow Check	1

ITEM	PART No.	DESCRIPTION	QTY
42	56-3346	3" Flue Adapter	1
45	26-3211	50V Transformer	1
46	02-4288	Breakout Board w/Wire Connectors	1
NS	02-4279	RS485 Communication Board	1
NS	02-4350	Protocarrrier	1
NS	70-1427	5K Resistor Assembly	1
NS	58-1831	5K Resistor	1
NS	70-2074	Harness (J2) Ctrl	1
NS	70-2075	Harness (J3) Ctrl	1
NS	70-2076	Harness (J4) Ignition/Flue Switch	1
NS	70-2077	Harness (J5) Blower/Gas Valve	1
47	02-5210	Blocked Flue Switch	2
48	45-1274	Ceramic Fiber Chamber	1
50	01-1640	Upper Casting Cover	1
51	58-1837	Blower	1
NS	06-00020	Blower to Swirlplate Gasket	1
NS	70-1651	Blower Assembly	1
NS	40-00268	Wire Harness (Blower to Inline)	1
NS	02-1584	Intake Adapter Flat	1
NS	02-1585	Intake Adapter Hose	1
52	57-3413	#6 X 1/2" Blk Screw	2
54	02-4290	Control Board w/Display	1
NS	60-5638	Control Overlay	1
NS	60-5628	Display Label	1
NS	70-1244	Drain Assembly	1
NS	70-1232	Condensate Drain Extension	1
NS	70-1660	Drain Pan Assembly	1
NS	42-2999	Rating Label	1
NS	13-00401	Air Vent	1

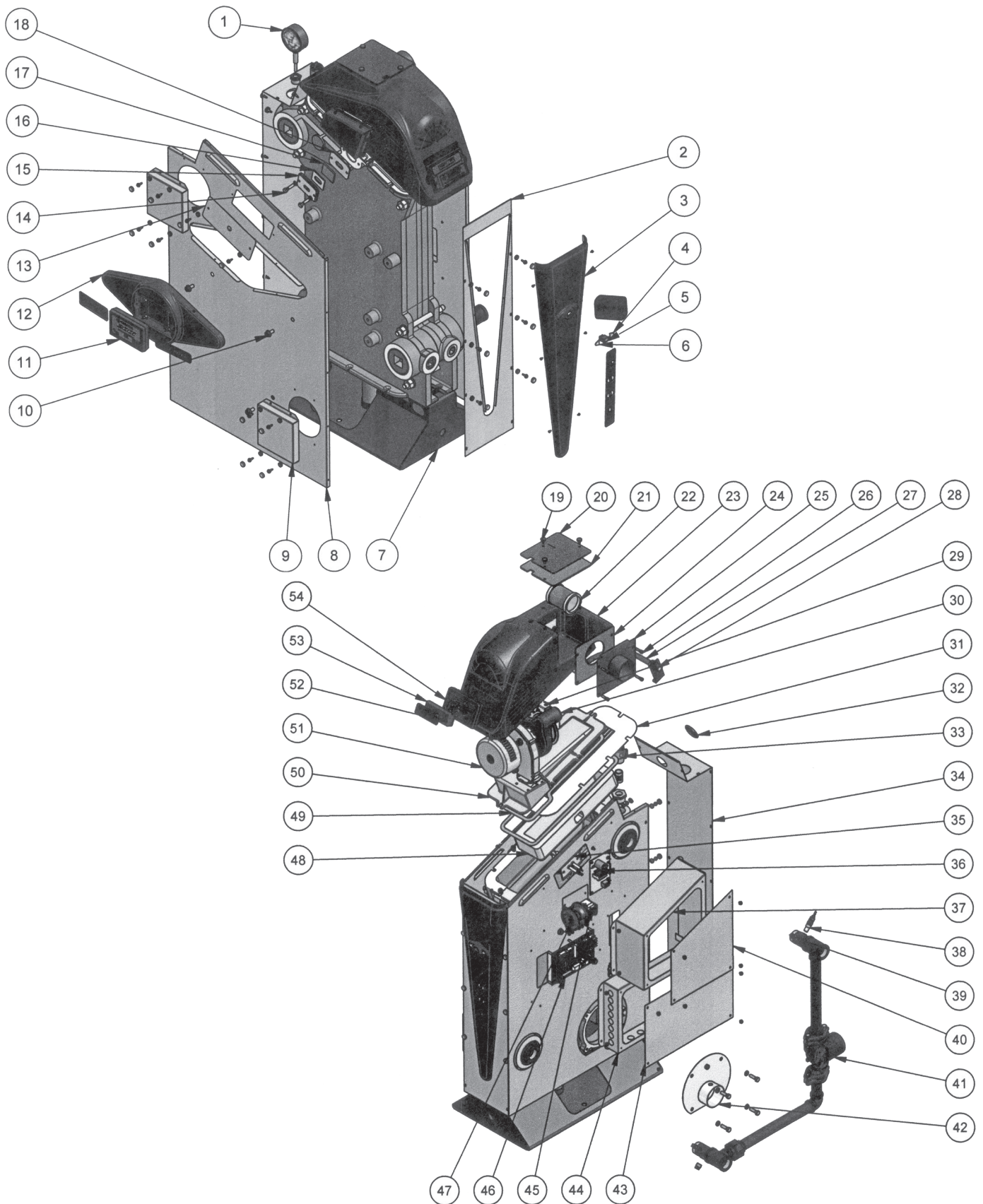
**15****KN-2 Replacement parts** *(continued)*

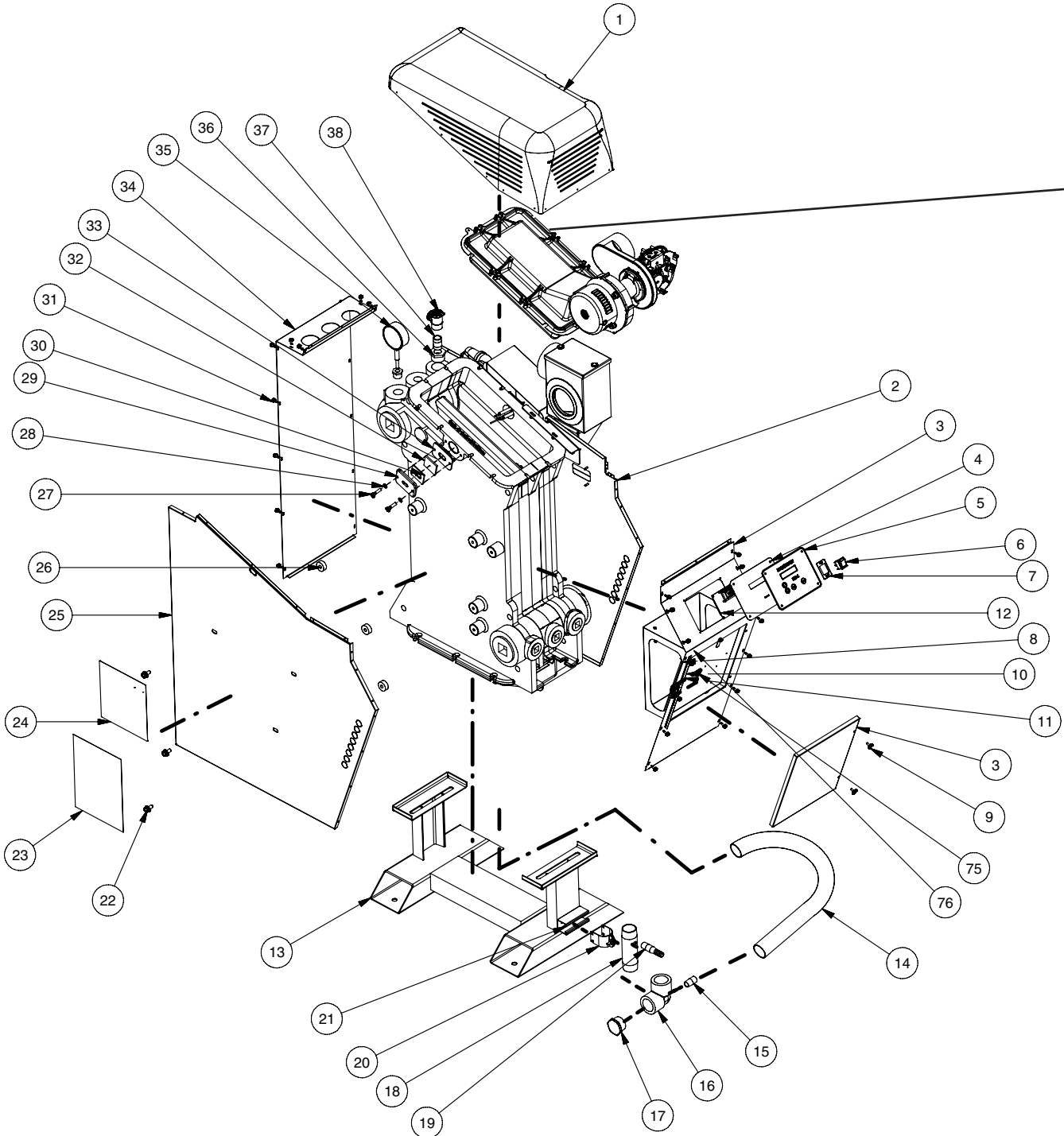
**15****KN-4 Replacement parts**

**KN-4 Replacement parts** *(continued)*

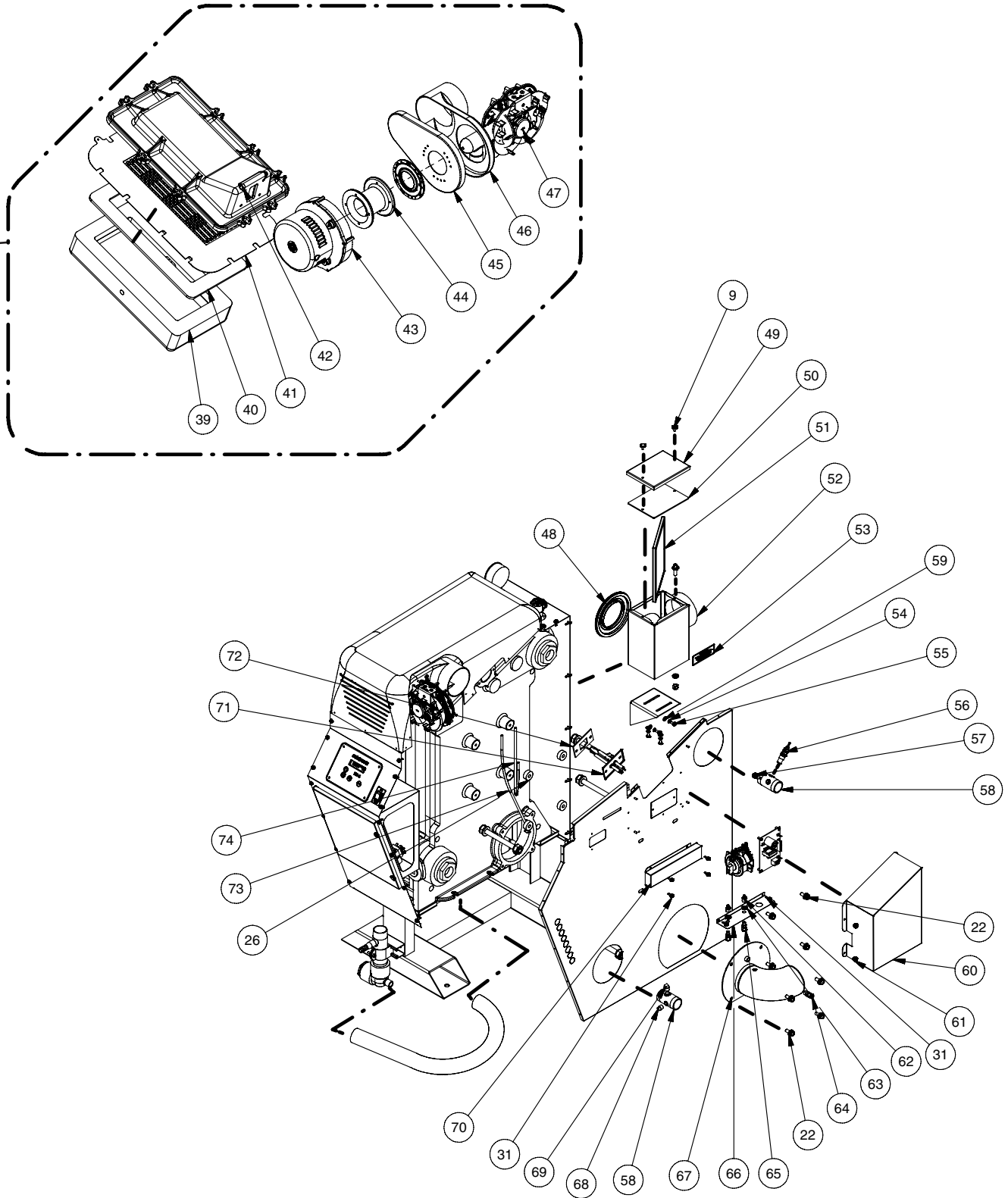



**KN-4 Replacement parts** *(continued)*

ITEM	PART No.	DESCRIPTION	QTY
1	60-5646	Upper Cover	1
2	70-1554	Jacket Assembly	1
4	03-1809	Display Mount Plate	1
5	60-5645	Control Overlay	1
6	58-1536	Illuminated Rocker Switch	1
8	02-4288	Breakout Board w/Wire Connectors	1
NS	02-4350	ProtocARRIER	1
NS	70-1427	5K Resistor Assembly	1
NS	58-1831	5K Resistor	1
NS	70-2074	Harness (J2) Ctrl	1
NS	70-2075	Harness (J3) Ctrl	1
NS	70-2081	Harness (J4) Ignition/Flue Switch	1
NS	70-2077.1	Harness (J5) Blower/Gas Valve	1
9	57-3657	Filter Box Thumb Screw	4
12	02-4291	Control Board w/Display	1
NS	01-1629	Front Section	1
NS	01-1627-1	Rear Section	1
NS	01-1628	Middle Section	1
14	54-3229	Tubing	1
24	42-2999	Rating Label	1
28	57-4701	5/16 Lock Washer	2
32	60-4280	Sight Glass	1
35	20-1022	T&P Gauge	1
38	22-1203	30 psi Relief Valve	1
38	22-1200	50 psi Relief Valve	1
38	22-1803	75 psi Relief Valve	1
38	22-1201	100 psi Relief Valve	1
39	45-1272	Ceramic Chamber	1
40	59-1096	Lower Chamber Gasket	1
41	70-1681	Burner Assembly	1

ITEM	PART No.	DESCRIPTION	QTY
	70-1209	Burner (Only)	1
43	58-1837	Blower	1
NS	40-00268	Wire Harness (Blower to Inline)	1
NS	06-00020	Blower to Swirlplate Gasket	1
44	01-1651	Inlet Adapter Casting	1
45	02-1590	Intake Adapter	1
46	02-1589	Air Intake Adapter	1
47	02-1581	Gas Valve	1
48	59-1115	Pipe Sealing Grommet	1
49	03-1811	Filter Box Cover	1
50	59-1113	Filter Box Gasket	1
51	59-1109	Combustion Air Filter	1
56	02-3928	High Limit Switch	1
57	02-3927	Operator - Supply Sensor	1
67	56-3345	4" Flue Adapter	1
71	70-6700	Ignitor Assembly	1
71	04-1344	Spark Rod	1
71	04-1345	Ground Rod	1
71	04-1346	Flame Sensor	1
71	59-2035	O'ring	3
72	59-1112	Ignition Block Gasket	1
75	26-3211	50V Transformer	1
76	02-4279	Communications Board	1
77	02-4296	Ignition Control	1
78	02-5210	Blocked Flue Switch	2
NS	70-1244	Drain Assembly	1
NS	70-1232	Condensate Drain Extension	1
NS	70-1683	Drain Pan Assembly	1
NS	13-00401	Air Vent	1

## Appendix A — suggested wiring

### IAR (Indoor Air Reset) wiring, when used Wiring for 3-wire zone valves without a zone controller

- Heat Demand terminal connections using 3-wire zone valves — The end switch leads from the zone valves must connect to the Heat Demand LEFT SIDE (+) terminal on the electrical connection board as shown in Figure A1.
- IAR connections — See Figure A1 for typical wiring to the IAR inputs when using 3-wire zone valves without a zone controller. For other applications, see the Control manual and Section 7 of this manual.

**CAUTION** **Polarity** — The connections to the **IAR** positive terminals (**IAR +**) must be to the same location on the zone valve as the thermostat wire, as shown in Figure A1. The connections to the **IAR** negative terminals (**IAR -**) must be from the zone valve terminal connected to the 24VAC common line, as shown. Connecting the wires incorrectly can cause the transformer to be shorted out and damaged.

**CAUTION** **3-wire zone valves:** You will have to rewire existing 3-wire zone valves to meet the requirements shown in Figure A1. Move the thermostat lead and the 24VAC hot lead to the **CENTER** terminal of the valve. Move the 24VAC common lead to the **outer** terminal of the valve. Discard existing wires connected to the end switch terminals. Install a new wire single wire from each end switch to the Heat Demand **LEFT SIDE (+)** terminal as shown in Figure A1.

**CAUTION** **3-wire zone valves:** Always use a voltmeter to verify the wiring is correct. The center terminal of the valve must be 24VAC to ground when the thermostat is calling for heat. The motor common terminal (outer post) must not have voltage. **DO NOT** connect the wires to the boiler until you have tested as described. Incorrect wiring can damage the boiler control or other system components.

- If there is only one transformer feeding all of the zone valves in the system, you can omit the wires to the **IAR** negative terminals (**IAR -**) on all but one of the zone valves. This is because these terminals are jumpered internally on the electrical connection board. If there is more than one transformer, provide one wire from each transformer common side to one of the **IAR** negative terminals (**IAR -**).

**Figure A1** Indoor Air Reset wiring to IAR terminals with 3-wire zone valves and no zone controller (see Figure 21a for terminal block **6** location)

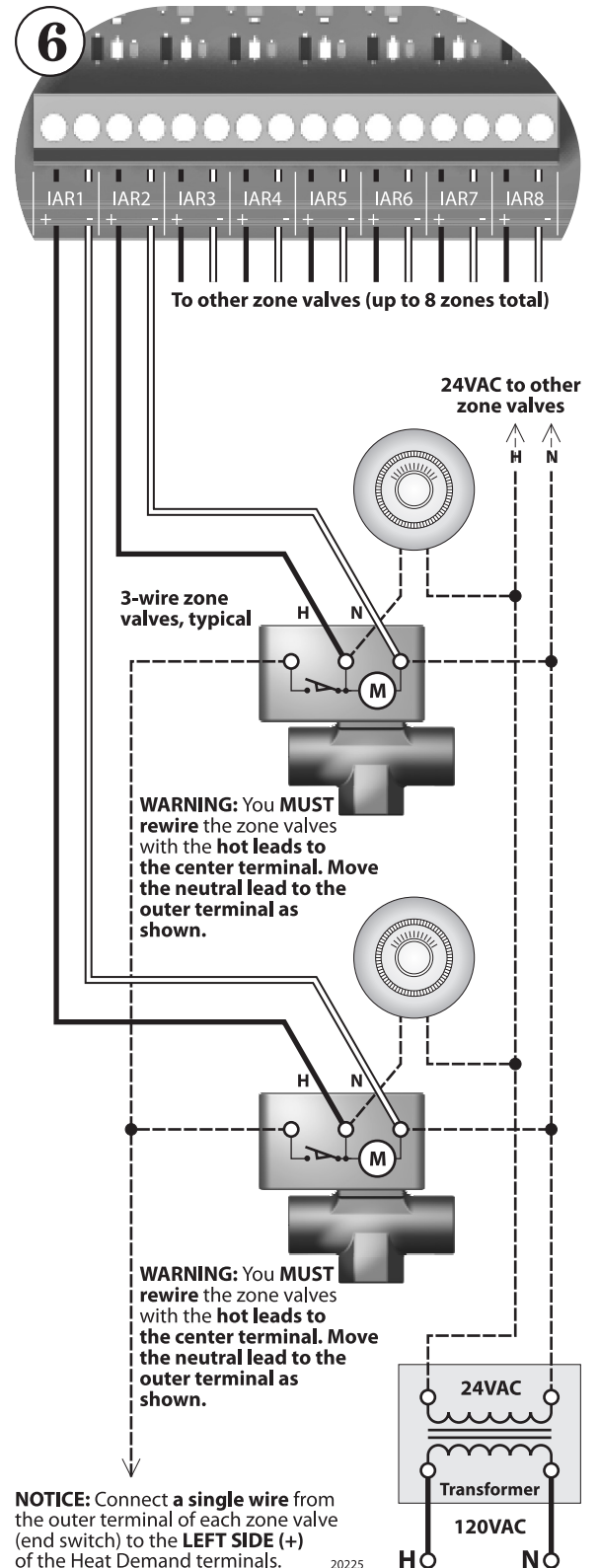

## Appendix A — suggested wiring *(continued)*

### IAR (Indoor Air Reset) wiring, when used Wiring for circulator relays (relays must have 24VAC common terminals)

**NOTICE** **Relays must have a 24VAC common terminal:** The IAR inputs require a connection to the 24VAC common of the circulator relay to operate. If the circulator relays do not have a 24VAC common terminal, you cannot connect to the IAR inputs. To operate with indoor reset, you will have to remove the existing relays and replace with a circulator zoning controller or install relays that provide a 24VAC common terminal.

- Heat Demand terminal connections using circulator relays — The end switch leads from the relays must connect to the Heat Demand terminals on the electrical connection board as shown in Figure A2.
- IAR connections — See Figure A1 for typical wiring to the IAR inputs when using circulator relays. For other applications, see the Control manual and Section 7 of this manual.

**CAUTION** **Polarity** — The connections to the **IAR** positive terminals (**IAR +**) must be as shown in Figure A2. The connections to the **IAR** negative terminals (**IAR -**) must be from the 24VAC common terminals of the circulator relays, as shown. Connecting the wires incorrectly can cause the transformer to be shorted out and damaged.

**NOTICE** **Verify 24VAC switched lead from thermostat:** Before connecting the wires to the IAR terminals, use a voltmeter to verify the 24VAC hot lead is NOT powered when the thermostat is not calling for heat.

**Figure A2** Indoor Air Reset wiring to IAR terminals with 3-wire zone valves and no zone controller (see Figure 21a for terminal block 6 location)

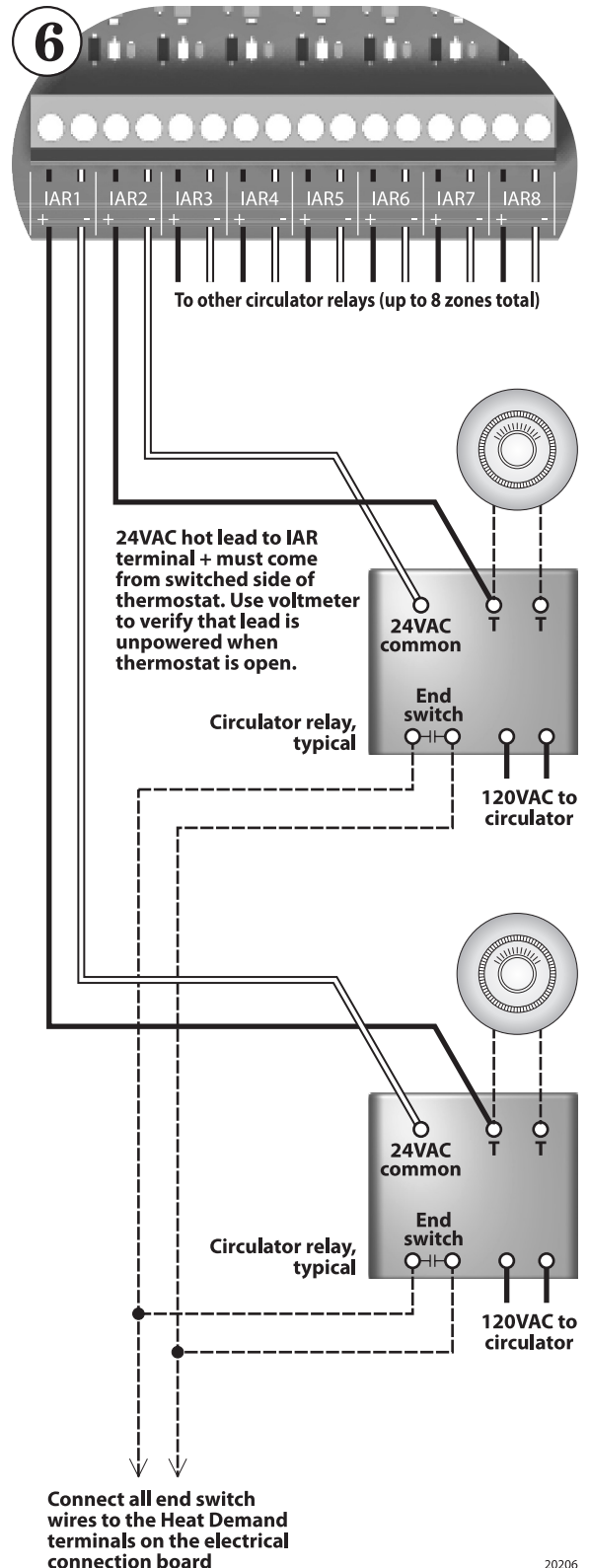

## Appendix A — suggested wiring *(continued)*

### IAR (Indoor Air Reset) wiring, when used Wiring for typical zone controller

- Heat Demand terminal connections — The end switch leads from the controller must connect to the Heat Demand terminals on the electrical connection board as shown in Figure A3.
- IAR connections — See Figure A3 for typical wiring to the IAR inputs when using a zone controller. For other applications, see the Control manual and Section 7 of this manual.

**CAUTION** **Polarity** — The connections to the **IAR** positive terminals (**IAR +**) must be to the same location on the zone valve as the thermostat wire, as shown in Figure A3. The connections to the **IAR** negative terminals (**IAR -**) must be from the zone controller's 24VAC common terminal as shown. Connecting the wires incorrectly can cause the transformer to be shorted out and damaged.

**NOTICE** **Thermostat terminal connections:** Use a voltmeter to verify the wiring is correct. Measure the voltage on the thermostat terminals with the zone controller powered, **BEFORE** connecting any wires. The IAR positive terminal connections (**IAR +**) must be to the side of the thermostat connections that have zero voltage.

**NOTICE** **DHW priority zone:** Most zone controllers will provide a priority zone for connection to a DHW tank aquastat and circulator. The priority switch will turn off space heating when there is a DHW call. Read the controller manufacturer's instructions to determine which zone is set up for priority operation.

**16**

**Appendix A — suggested wiring** *(continued)*

**Figure A3** Indoor Air Reset wiring to IAR terminals, Heat Demand and DHW Demand using typical zone controller for either circulators or zone valves (see Figure 21a for terminal block 2 and 6 locations)

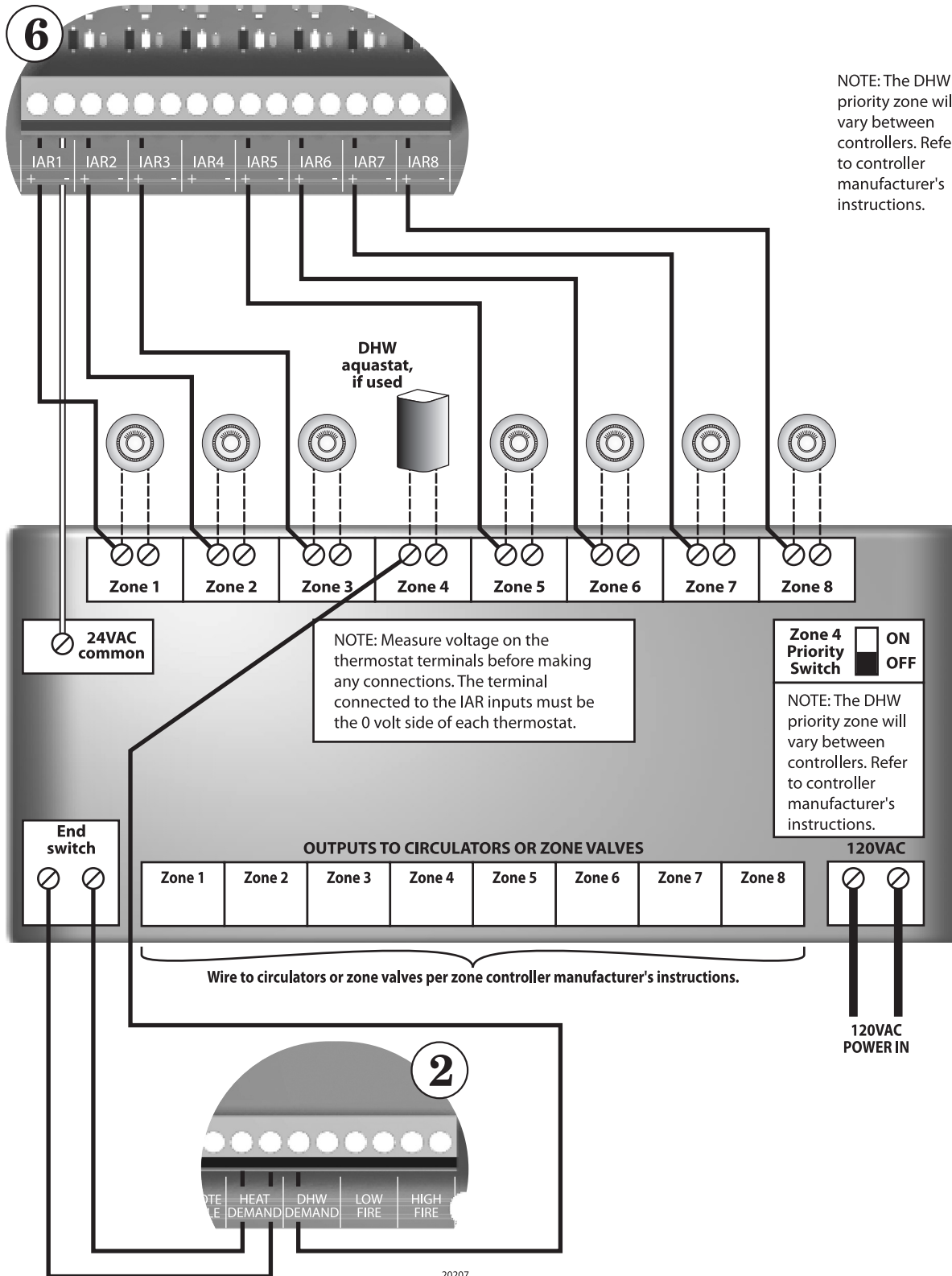

20207



## Start-up & service history

Installation and start-up (complete before leaving installation site)			
Start-up date	Boiler model	Serial number	Installer/start-up company name and address: _____
Fuel (natural or LP)	High fire CO <sub>2</sub> (O <sub>2</sub> )	High fire CO	
Low fire CO <sub>2</sub> (O <sub>2</sub> )	Low fire CO	Metered input, Btuh	Technician _____
Flame current	Gas supply pressure		Phone _____
Check off each item listed below to indicate the work was performed and all installation aspects agree with boiler manuals			
<input type="checkbox"/> System and boiler filled with water	<input type="checkbox"/> Ignition control tested for ignition failure	<input type="checkbox"/> Additional comments below: _____	
<input type="checkbox"/> System flushed before filling	<input type="checkbox"/> HeatNet control adjusted per Control manual		
<input type="checkbox"/> Water chemistry tested/regimen established	<input type="checkbox"/> Vent/air piping installed correctly		
<input type="checkbox"/> Air purged from water system	<input type="checkbox"/> Boiler operated through several cycles		
<input type="checkbox"/> Air vents checked and opened as needed	<input type="checkbox"/> Limits and interlocks tested		
<input type="checkbox"/> Water piping correct and operational	<input type="checkbox"/> Metered gas input (natural gas)		
<input type="checkbox"/> Gas supply pressure tested/verified	<input type="checkbox"/> DHW system tested, if applicable		
<input type="checkbox"/> Gas supply piping correct	<input type="checkbox"/> Explained User's manual to owner		
<input type="checkbox"/> Flame observed and combustion tested	<input type="checkbox"/> Instruction manual will be kept at site		
Service history (complete before leaving boiler site after service)			
Service date	Technician	Service company/address _____ _____ _____	Describe service performed
Service date	Technician	Service company/address _____ _____ _____	Describe service performed
Service date	Technician	Service company/address _____ _____ _____	Describe service performed
Service date	Technician	Service company/address _____ _____ _____	Describe service performed



IN UNITED STATES: 260 NORTH ELM ST. • WESTFIELD, MA 01085 • (833) 265-5371  
IN CANADA: 7555 TRANMERE DRIVE • MISSISSAUGA, ONT. L5S 1L4 • (905) 670-5888  
[www.knseries.com](http://www.knseries.com)